



MAGNUM HEATING

Comfort | Safety | Control



Product catalogue
2024

About us

In 3 decades MAGNUM Heating has grown into a successful, market-leading and brand-oriented European designer, manufacturer and supplier of innovative electrical and water-based heating systems and related products.

Durable

Our systems have a very long life span and respond perfectly to the fundamental energy transition from fossil heating sources to sustainable climate solutions.

In-house production

We manufacture and assemble most products ourselves in our own production departments. This way, we control the process from beginning to end and ensure optimum quality control. This makes us the most reliable supplier of heating products.

MAGNUM Heating B.V. is part of the MAGNUM Heating Group B.V.



MAGNUM Heating B.V.
Stevinweg 8
4691SM Tholen

T +31(0)166 - 609 300
E info@magnumheating.com
W magnumheating.com

KvK 22043037
BTW NL8074.91.950.B01
IBAN NL37INGB0655775129
BIC/SWIFT INGBNL2A

Table of contents

General information

Endless Comfort	4	Underfloor heating selection guide	10	Safety first	17
Sustainability and energy transition	6	Distributor selection aid	12	About MAGNUM Heating	18
Efficient at every level	7	Full control	14		
Underfloor heating for every situation	8	Mirror and ceiling heating	16		

Electrical systems

Underfloor Heating Renovation		MAGNUM Heatboard E Cable	34	MAGNUM IsoFoam	44
MAGNUM Mat Set	20			MAGNUM IsoPlate	45
MAGNUM Mat	22	Ceiling Heating		MAGNUM DuoBoard	46
		MAGNUM Sol	36	MAGNUM Contact adhesive	47
Underfloor Heating New build		MAGNUM Sol Premium IP54	38		
MAGNUM Cable 17W Set	24			Thermostats	
MAGNUM Cable 17W Los	26	Mirror Heating		MAGNUM Remote Control WiFi	48
MAGNUM Cable 10W Los	28	MAGNUM Look	40	MAGNUM Z-Wave Control WiFi	50
				MAGNUM F32 WiFi	52
Underfloor heating Dry construction		Accessories		MAGNUM S-Control On/Off	54
MAGNUM Foil Set	30	MAGNUM IsoRoll	42		
MAGNUM Heatboard E Systemplates	32	MAGNUM Edge insulation	43		

Waterborne systems

Floor & wall Heating Renovation				Pump/temperature regulator	82
MAGNUM SlimFit 10	56	Floor Heating pipe		Accessories	
MAGNUM SlimFit 12	58	MAGNUM Tube	70	Adaptor/Euroconus	84
MAGNUM Fiberboard	60			Floor insulation & accessories	85-89
		Manifolds with pump			
Underfloor Heating New build		MAGNUM Basic Steel	72	Thermostats	
MAGNUM Tacker Plates	62	MAGNUM Front Steel	74	MAGNUM Remote Zone Wireless	90
MAGNUM Castellated Plates	64	MAGNUM Premium Kunststof	76	MAGNUM H64 Wired	92
Underfloor Heating Dry construction		Open manifolds			
MAGNUM HeatBoard W	66	MAGNUM Stainless Steel Open	78		
MAGNUM DryFloor	68	MAGNUM Plastic Open	80		

Outdoor systems

Ramp heating		Frost free ribbon		Tracing accessories	
MAGNUM Outdoor Cable Asphalt	94	MAGNUM Ideal frost free ribbon	102	Connection units	116
MAGNUM Outdoor Cable Concrete	96			Other accessories	118
		Tracing			
Driving track heating		MAGNUM Trace Regular	104	Outdoor/Tracing regeling	
MAGNUM Outdoor Mat	98	MAGNUM Trace Micro	106	Thermostats	120-127
		MAGNUM Trace Micro Plug & Go	108	Sensors	128-132
Outdoor Switchboards		MAGNUM Trace Water	110		
MAGNUM Outdoor Switchboards	100	MAGNUM Trace Hot Water	112		
		MAGNUM Trace Gutter Heat	114		





Home is where the warmth is.

Endless comfort

Underfloor heating offers the most comfortable way of heating. Due to the uniform heat radiation from the entire floor surface, a very even heat distribution is created. The floor will quickly reach a pleasant temperature.

Infrared heat or radiant heat works just like in nature: heat waves from the sun reach the wall of your home during the day, for example. Heat

is stored in this wall, which is then emitted again after a delay. In the evening, the ambient air cools down and the release of residual heat from the wall is clearly felt. An underfloor heating system works on the same principle.



Transit of energy

We are rapidly moving away from gas and switching to renewable energy sources. The innovation in this is going fast, but we have only just started. Whether it concerns the renovation of an old or an entirely new house to be built, our systems are already prepared for the future in order to provide maximum comfort for your situation, now and in the future.

A sustainable home

In many situations it is possible to install underfloor heating as the only heat source (main heating). If the insulation value of the house is not sufficient, for example in an older house, extra insulation and possibly installing wall heating can still achieve a high heat output.

“On the road to a sustainable future.”



The difference

With radiant heat (underfloor heating), the heat is emitted directly so that the room is heated more evenly and more quickly felt. Traditional convection heating only heats the air. Warm air has the property that it rises so that the temperature at the ceiling is significantly higher than close to the floor. Consequence: cold feet and a warm head.

Lower temperature

Underfloor heating offers enormous comfort at a lower temperature. By setting the lowering temperature of the system not lower than 50C, the heat remains in the floor mass. It takes less energy to bring the system back up to temperature than to let the floor cool down further each time. Not only the temperature is lower, but also your energy bill!

Insulation is the key

A well-functioning system strongly depends on the insulation value of your house. By first applying a good insulation you limit the heat loss downwards. The floor will retain the heat longer as a result. After all, underfloor heating works more efficiently with a well insulated subfloor.

Efficiency and comfort at every level.



Underfloor heating for every situation.

Choosing the right underfloor heating for your situation is simple. A heating demand can easily be divided into 3 categories: New build, Renovation or Dry build.

New build systems can be installed directly in the cement screed. This allows more mass to be heated and the heat output is optimal.

For renovations it is important that systems can be applied without far-reaching interventions (such as milling). The minimum installation height of

these systems ensures that they can be installed on an existing floor and even in the wall, so that no radiators are needed.

Wood and laminate floors require weather systems that keep the temperature below 28°C in connection with the (natural) functioning of these floor coverings.

There is a solution for every heating demand.

“Good insulation is the key to an efficiently functioning system.”

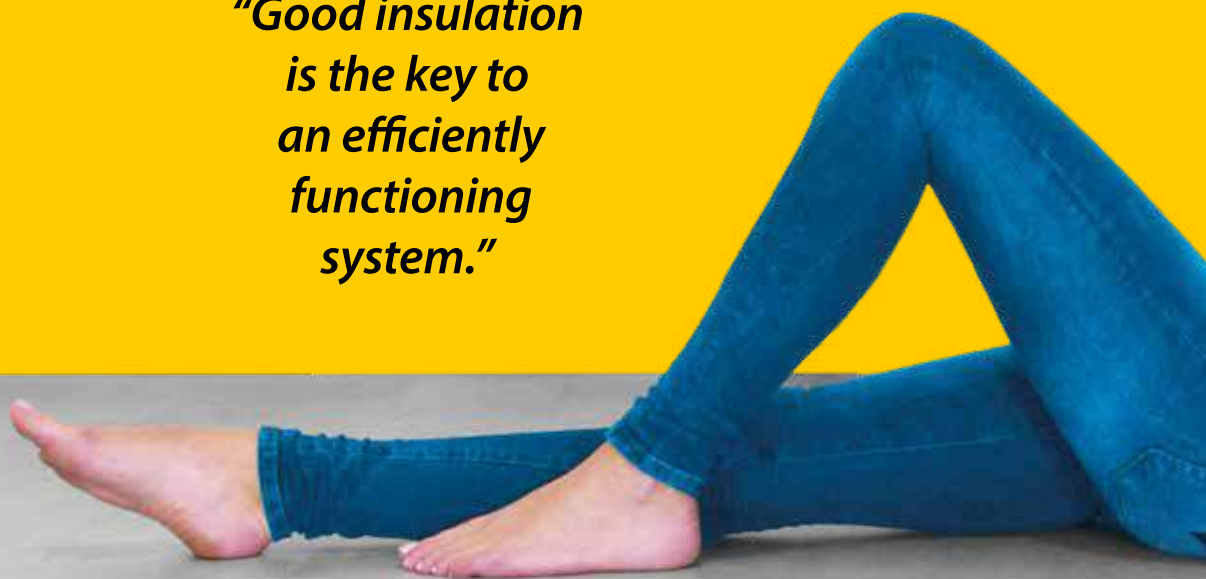

Renovation



MAGNUM Mat



MAGNUM SlimFit 10 & 12

New Build

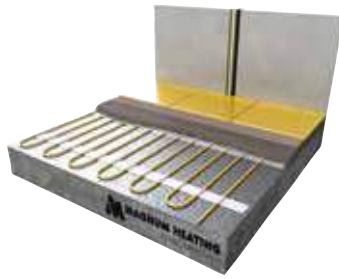

MAGNUM Cable

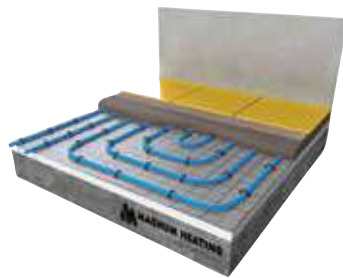

MAGNUM Tacker Plates



MAGNUM Castellated Plates

Dry Floor

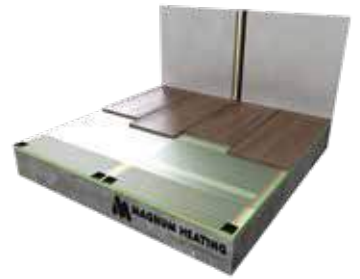

MAGNUM Foil



MAGNUM HeatBoard E



MAGNUM HeatBoard W



MAGNUM DryFloor



Underfloor heating selection guide

Renovation (floor & wall)

Electric

Available installation height
Excluding floor finish:
5 - 15 mm

MAGNUM Mat Set
incl. MRC WiFi thermostat

MAGNUM Mat

Option: MAGNUM IsoPlate (6 or 10mm)

Additional insulation layer or as reinforcement on wooden subfloor

Suitable thermostats:
MRC WiFi thermostat
MAGNUM Z-Wave
MAGNUM S-Control

Water based (also for new buildings!)

Available installation height
Excluding floor finish:
15 - 20 mm

MAGNUM Slimfit 10
Set of system plates per 2,4m²

MAGNUM Tube 10x1,3mm
± 8 m Tube per m²

Available installation height
Excluding floor finish:
15 - 25 mm

MAGNUM Slimfit 12
Set of system plates per 3,75m²

MAGNUM Tube 12x1,5mm
± 8 m Tube per m²

Suitable distributor:
See distributor selection aid

Connection couplings
10 x 1,3 mm (set of 2)

Connection couplings
12 x 1,5 mm (set of 2)

Suitable thermostats:
Wired or wireless

New build

Electric

Available installation height
Excluding floor finish:
25 - 50mm

MAGNUM Cable Set
incl. MRC WiFi thermostat

MAGNUM Cable
10 of 17W/m¹

Options:

Isorol, Alutape, Spacerstrips, Edge insulation, Stabilisator fibers etc.

Suitable thermostats:
MRC WiFi thermostat
MAGNUM Z-Wave
MAGNUM S-Control

Water based

Available installation height
Excluding floor finish:
40 - 60mm

Tacker grid foil
Rol per 50 m²

Non insulates Castelated plates
Set per 10 m²

MAGNUM Tube 14-20 mm

MAGNUM Tube 14-16 mm

Tacker staples and -stapler

Dry Construction

Electric

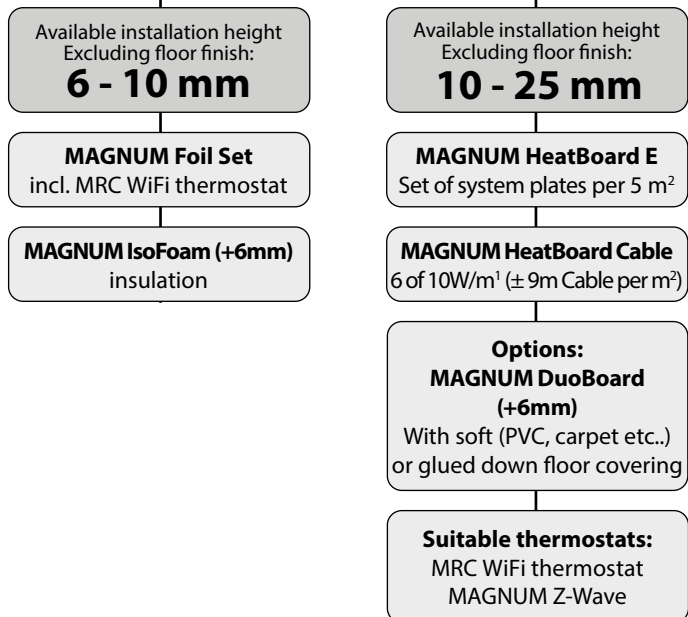

Water based

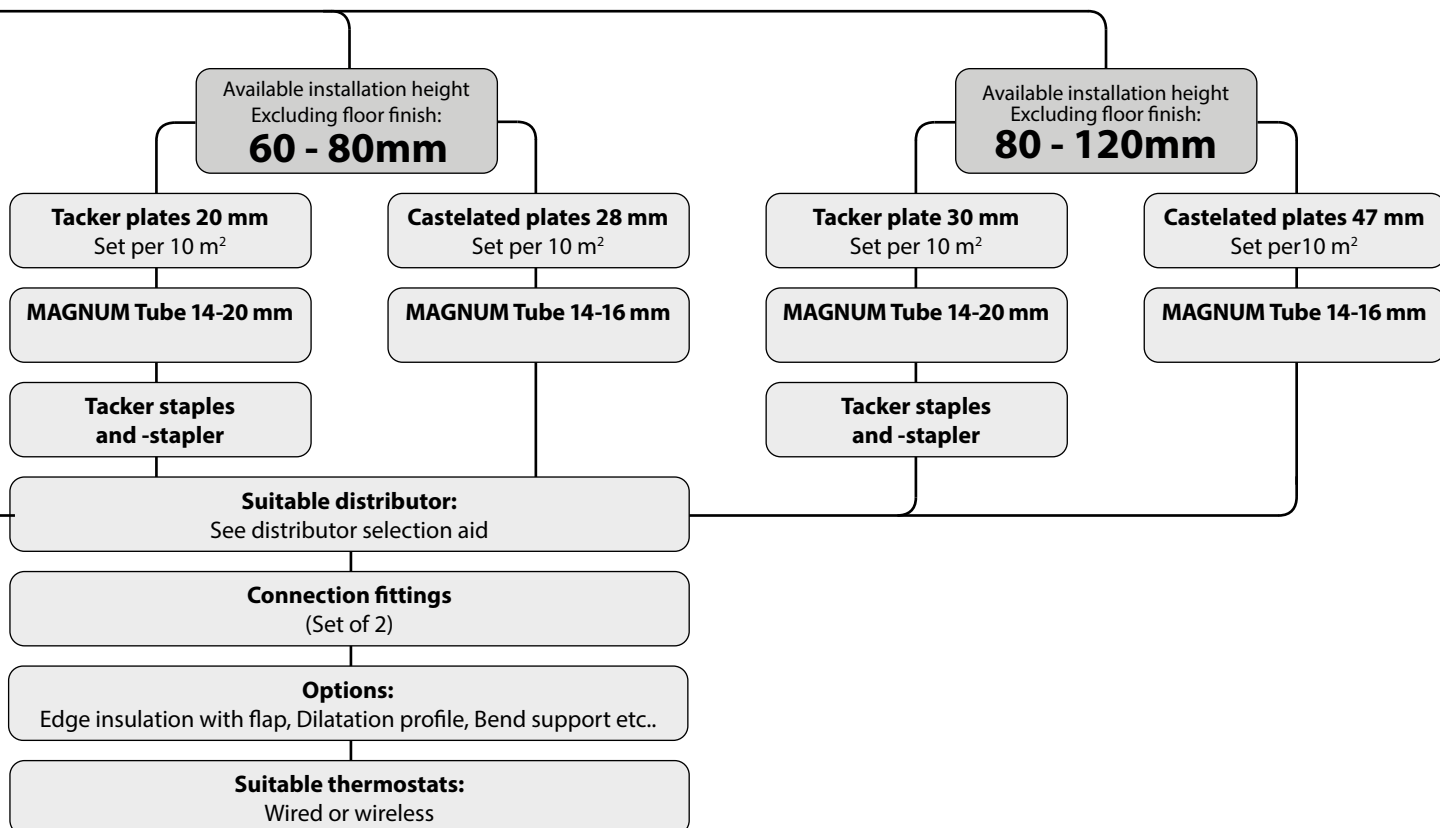
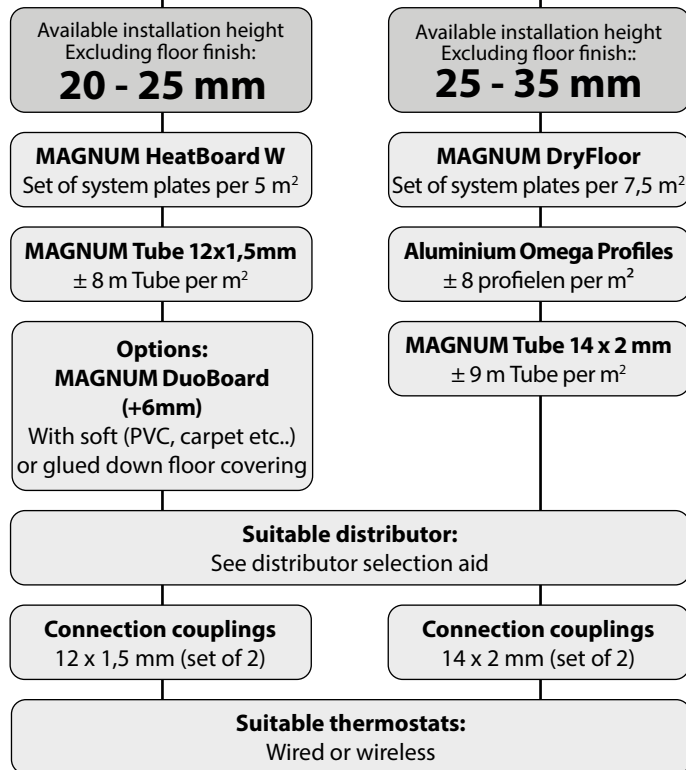

Distributor selection guide

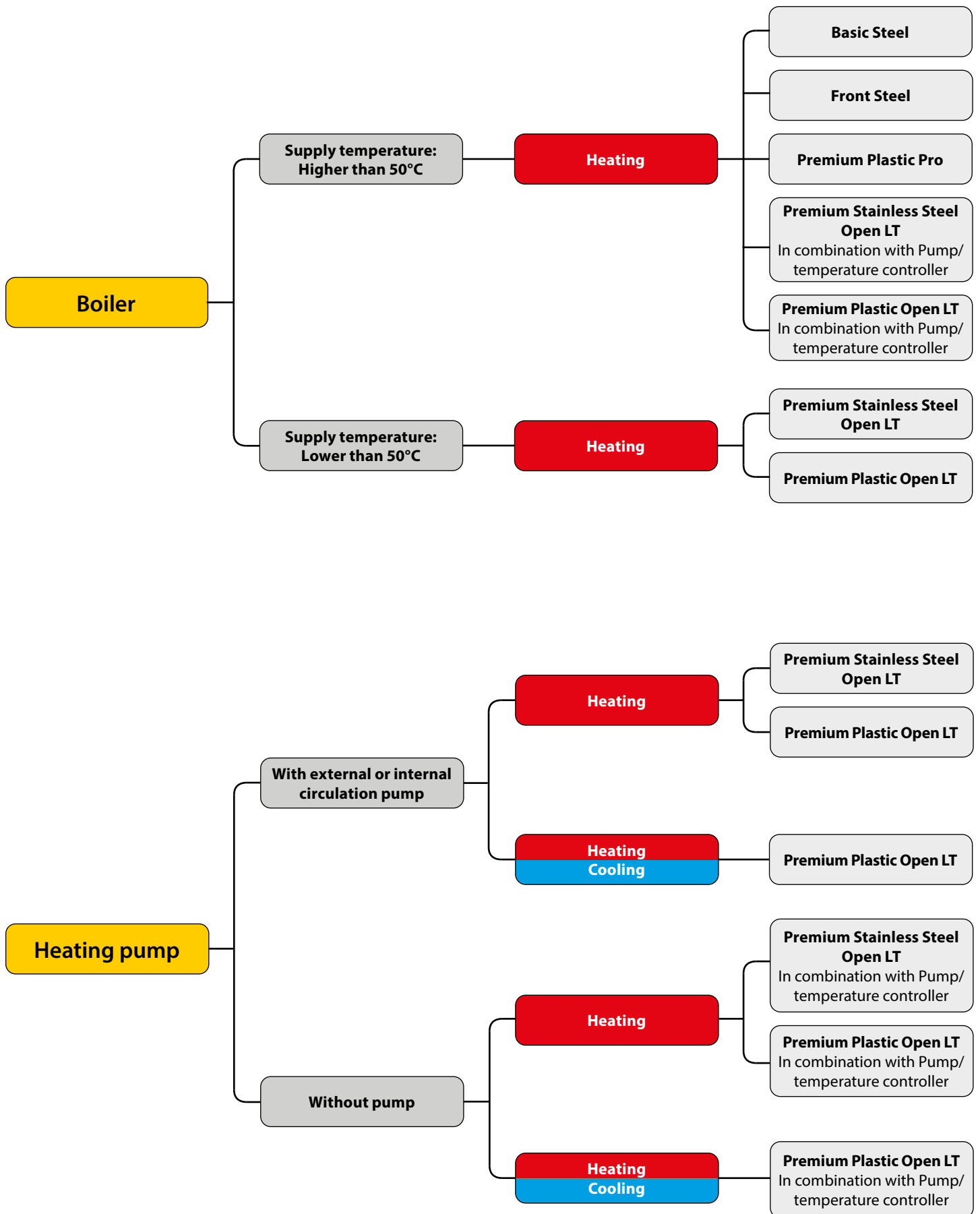

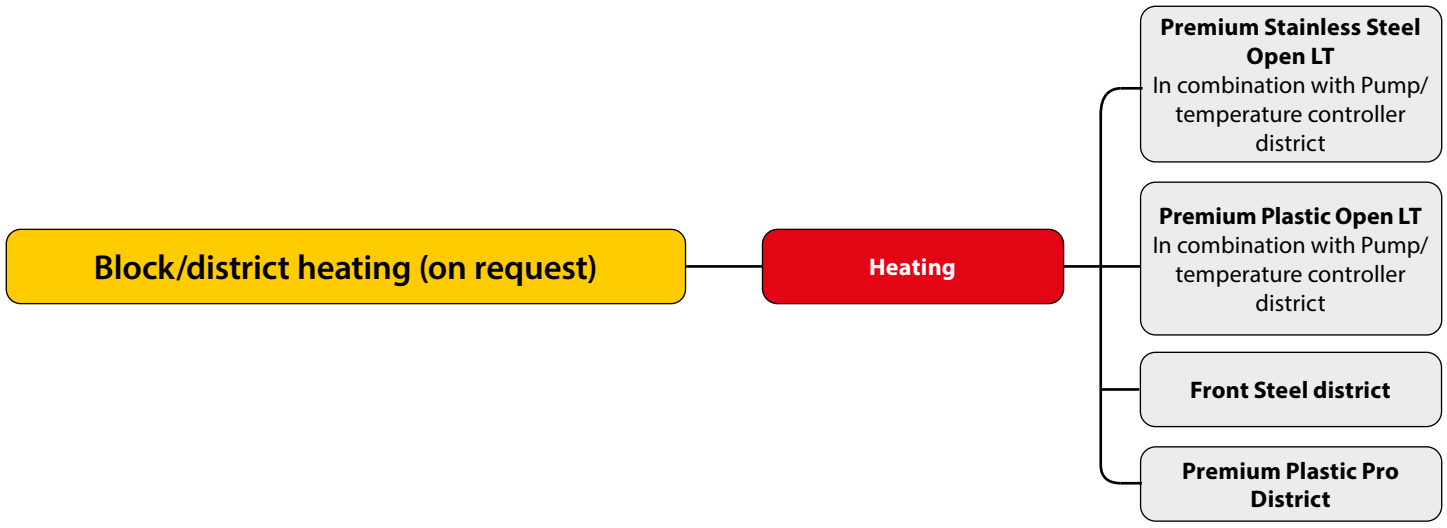
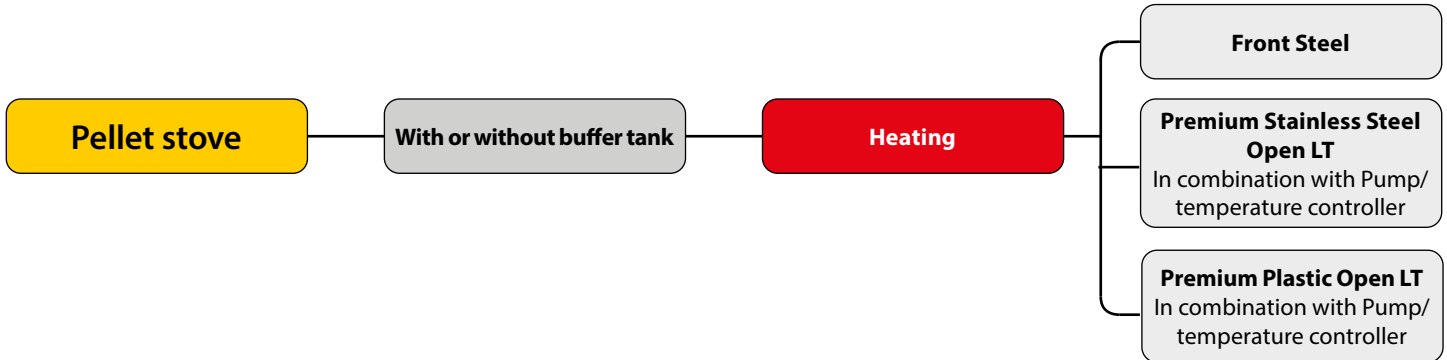
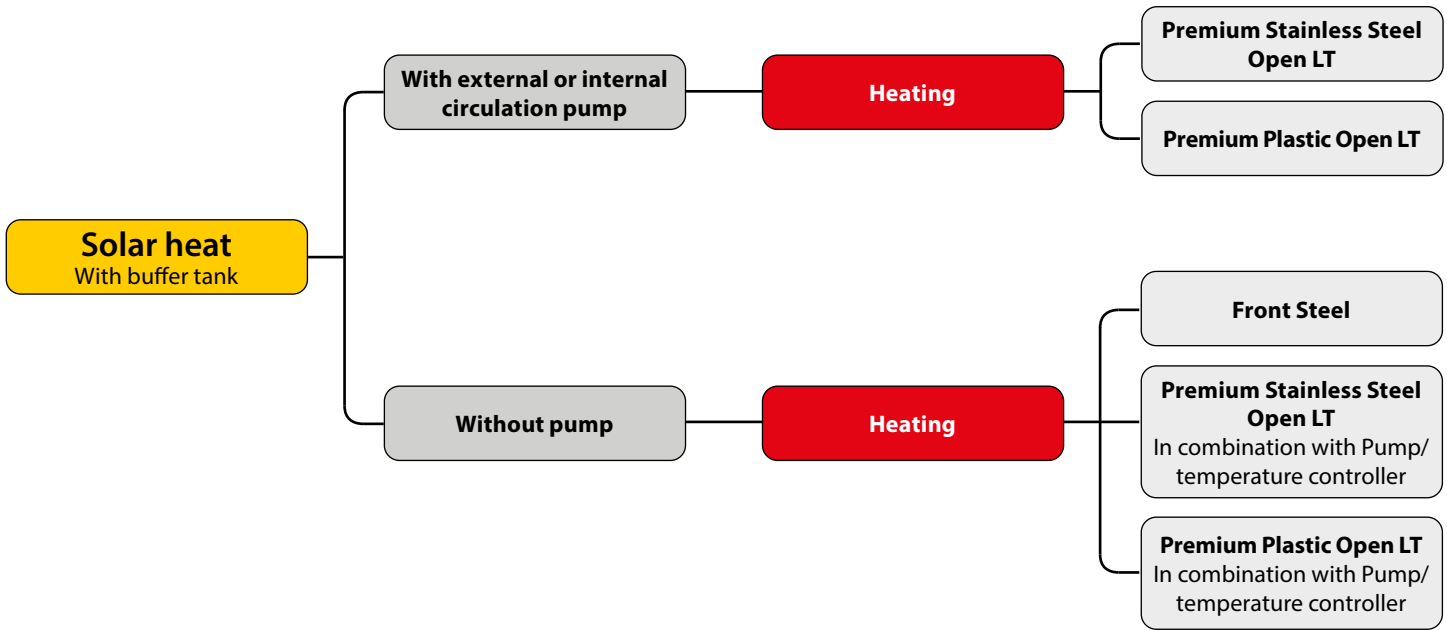

Full control. Even when you're not at home.



Intuitive design

In the development of our thermostats, in addition to a lot of technical aspects, we take user-friendliness as our starting point. The smart MAGNUM MRC WiFi thermostat, for our electrical systems, is easy to program and operate. Equipped with step-by-step instructions for trouble-free setting of the desired times and temperatures.

Cleverly controlled

The MRC is equipped with an automatic intelligent function: All you have to do is enter the periods in which you want to have a warm floor. It gradually learns the ideal warm-up time of the floor and automatically adjusts its program accordingly. So if you set that you want the floor to be at 23°C at 7:00 AM, the thermostat will do the rest.



Zone control

MAGNUM Remote Zone Control is a complete system for controlling your underfloor heating. The system consists of thermostats that can be hung in any room and a controller that is mounted at the distributor. Control the zones separately via the thermostat or via your tablet or smartphone. This allows you to set up the various zones in your home with the greatest of ease.

The MAGNUM W-Thermostat ensures precise control of the room temperature. With this clock thermostat you can adjust the temperature based on a series of programmed settings that come into effect at different times of the day.

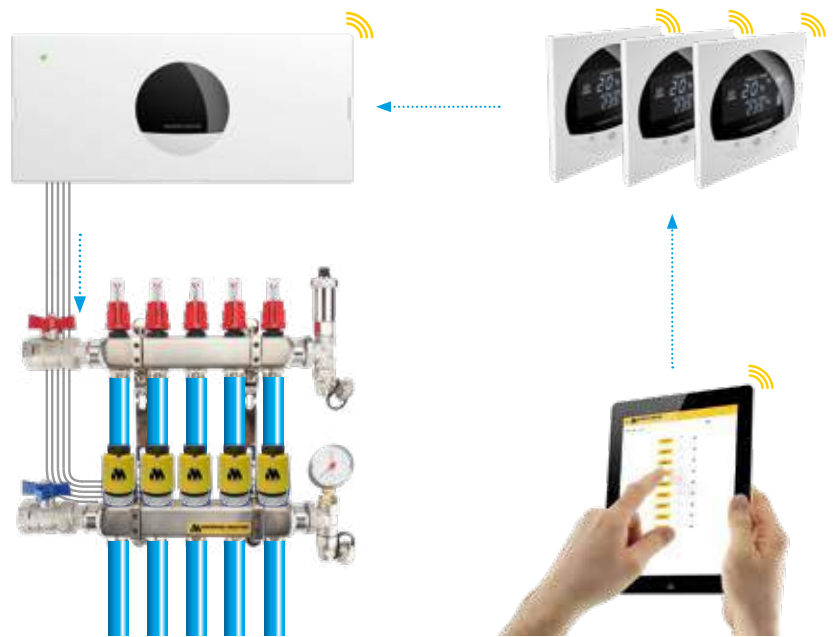

Optimal precision

Our products are designed in view of the strongly changing climate in Europe where the outside temperature can fluctuate strongly within a few hours. This requires control equipment that responds quickly and accurately. Our thermostats think ahead themselves and calculate the required warm-up times and the amount of energy needed to do so.

Thanks to precise control, an optimal and comfortable living climate is possible everywhere. In addition, our systems can easily be linked to new or existing automation systems, so you no longer have to worry about them. Even when you're not at home.

MAGNUM thermostats have been developed in-house and are among the most reliable on the European market.



Ceiling heating

MAGNUM Sol ceiling radiant heaters can be installed in a suspended ceiling and offer maximum freedom in designing the interior of any office, showroom or shop. With the integrated suspension bracket, the panels can also be fixed directly to any other ceiling.

If you are looking for an extra source of heat in your bathroom, the MAGNUM Sol Premium ceiling radiant heaters are the solution. These panels have an IP54 standard and are therefore very suitable for wet rooms.

These ceiling radiant heaters heat everything within the radiation range in a very short time. This makes them ideal for rooms that do not have a continuous occupancy and need to be warmed up in a short time.



A clear view

Always a condensation-free mirror thanks to a very simple solution. MAGNUM Look electric mirror heating is stuck directly on the back of the mirror and is an indispensable addition to your bathroom, it prevents condensation from forming in “no time”.

Connect the mirror heating directly to the existing light switch and the heating element will only be switched on during your presence in the bathroom. This way you save energy!

Safety first. Without compromise.

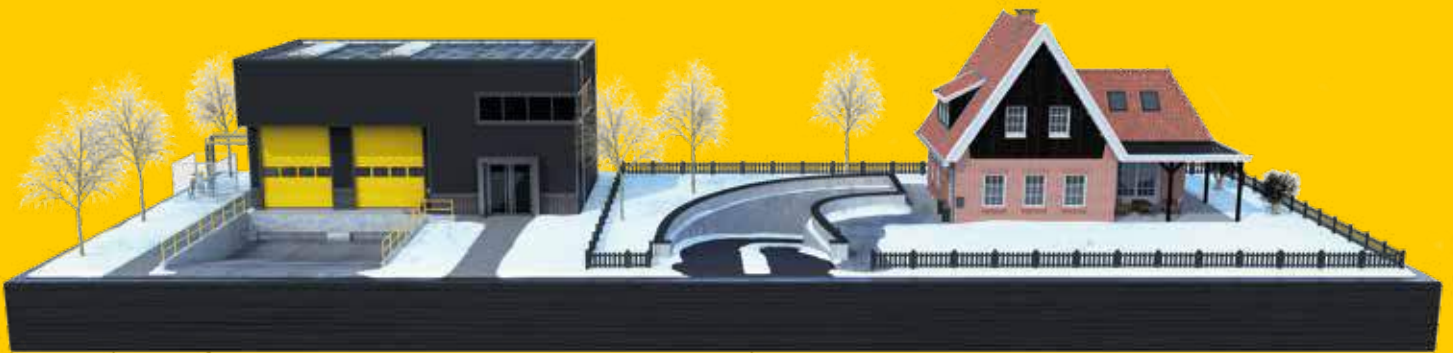

Exceptionally safe

Safety, prevention and continuity are the key words that justify an investment in the construction of a frost-free installation. Especially for ramps and exits at an angle of inclination of distribution centres, car parks, hospitals, fire stations, office buildings, etc. The MAGNUM Outdoor system offers you safety and reliability

at minimum investment, consumption and maintenance costs.

The MAGNUM Trace range offers total solutions for keeping (water) pipes, gutters and drains frost-free. There is also a plug-in frost-free tape available with built-in thermostat.

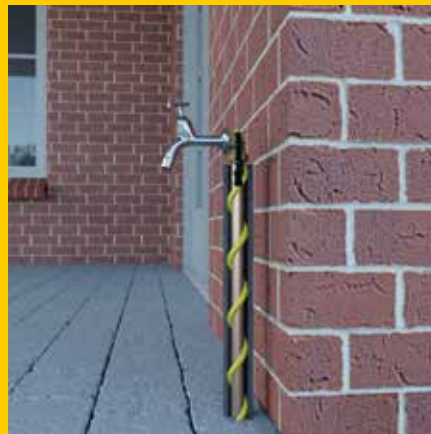





Prepared for a sustainable future.

Know-How

Over the past 3 decades, MAGNUM Heating has grown into a successful, market-leading and brand-oriented European designer, manufacturer and supplier of innovative electric and waterborne heating systems and related products. We have a continuous focus on innovation, supported by our customers.

Sustainable

Our systems have a very long lifespan and respond perfectly to the fundamental energy transition from fossil heating sources to sustainable climate solutions. We are continuously active to refine production and logistic processes in order to make our carbon footprint as small as possible.

Own manufacturing

We manufacture and assemble most products ourselves in our own production departments. In this way, the process is kept in our own hands from start to finish and there is optimal quality control. This makes us the most reliable supplier of heating products.

More information?

Our products are available from any authorised E & W installer or bathroom specialist. They usually also advise and take care of the installation.

Would you like more information in the meantime?

Visit magnumheating.nl or call 0166 - 609 300 during office hours.

MAGNUM Mat (Set)

Underfloor heating mat

The MAGNUM Mat is a unique underfloor heating mat. The system is designed to allow underfloor heating to be installed over an existing tiled floor or on top of a screed that has already been installed. The mat is approximately 4 mm thin and can be included in an adhesive layer without demolition and milling out. The mat is placed almost directly under the surface. This increases the heating rate of the floor which also makes the system suitable for areas with non-permanent occupancy such as bathrooms, hobby rooms, recreation rooms etc.

The advanced WiFi thermostat takes into account the necessary warm-up time, so your floor will always be the right temperature at the desired time.

MAGNUM Mat is available in 22 different sizes from 0,75 to 25m². Because the heating cable on the mat is connected at the end, there is only one side with a power cable, which is invisibly attached through a unique blind connection. This means that there is no need for a return to the thermostat.



Installation in self-levelling compound

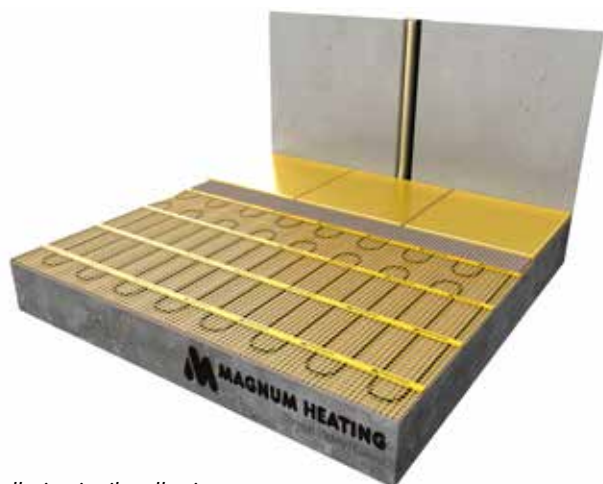

Installation in tile adhesive

Specifications

System type	Electric
System height	4 mm
System width	25 or 50 cm
Min. setting height	10 mm
Installation	Self-levelling / Tile adhesive
Power	125 or 150W/m ²
In wet areas	✓
Tiles	✓
Wood	✓ (i.c.w. self-levelling)
(PVC) Laminate	✓ (i.c.w. self-levelling)
Carpet	✓ (i.c.w. self-levelling)
Certification	CE, VDE
Warranty	Lifetime*



REG.-Nr. 40041320



Unieke blinde verbinding tussen verwarmings- en aansluitkabel

Technical details

- EMC-free, 2-conductor cable attached to fiber optic network
- 3,5 meter three-wire power cable
- Full enclosure by aluminum sheath
- Unique blind connection between heating and connection cable
- Chrome/Nickel resistance wire
- PTFE (Teflon) insulation
- PVC protective sheath
- Cable diameter approx. 4 mm
- Mat width 25 or 50 cm
- Meets current NEN standards for installation in entire wet area

Installation methods

- Directly into tile adhesive
- Self-levelling casting mortars
- In plaster/mortar
- Anhydrite floors
- MAGNUM Mat is not suitable for use in lightweight concrete

Package contents

- Heating mat
- MAGNUM Remote Control WiFi thermostat incl. floor sensor
- Flexible tube for floor sensor
- Installation instructions & Check/Control card

Warranty

Lifelong* warranty on the electrical operation of the heating mat and 2 years on the thermostat and floor sensor.

*See conditions on: magnumheating.com

Art.nr. white	Art.nr. black	Description	m ²	Power	W per m ²	Amps	Ohm	Dimension
200075	210075	MAGNUM Mat Set	0,75 m ²	113 Watt	150 Watt	0,6	468	0,25 x 3,00 m
200205	210205	MAGNUM Mat Set	1,0 m ²	150 Watt	150 Watt	0,7	353	0,50 x 2,00 m
200125	210125	MAGNUM Mat Set	1,25 m ²	188 Watt	150 Watt	0,8	281	0,25 x 5,00 m
200305	210305	MAGNUM Mat Set	1,5 m ²	225 Watt	150 Watt	1,0	235	0,50 x 3,00 m
200175	210175	MAGNUM Mat Set	1,75 m ²	263 Watt	150 Watt	1,1	201	0,25 x 7,00 m
200405	210405	MAGNUM Mat Set	2,0 m ²	300 Watt	150 Watt	1,3	176	0,50 x 4,00 m
200225	210225	MAGNUM Mat Set	2,25 m ²	338 Watt	150 Watt	1,5	157	0,25 x 9,00 m
200505	210505	MAGNUM Mat Set	2,5 m ²	375 Watt	150 Watt	1,6	141	0,50 x 5,00 m
200605	210605	MAGNUM Mat Set	3,0 m ²	450 Watt	150 Watt	2,0	117	0,50 x 6,00 m
200705	210705	MAGNUM Mat Set	3,5 m ²	525 Watt	150 Watt	2,3	100	0,50 x 7,00 m
200805	210805	MAGNUM Mat Set	4,0 m ²	600 Watt	150 Watt	2,6	88	0,50 x 8,00 m
200905	210905	MAGNUM Mat Set	4,5 m ²	675 Watt	150 Watt	2,9	78	0,50 x 9,00 m
201005	211005	MAGNUM Mat Set	5,0 m ²	750 Watt	150 Watt	3,3	71	0,50 x 10,00 m
201205	211205	MAGNUM Mat Set	6,0 m ²	900 Watt	150 Watt	3,9	59	0,50 x 12,00 m
201405	211405	MAGNUM Mat Set	7,0 m ²	1050 Watt	150 Watt	4,6	50	0,50 x 14,00 m
201605	211605	MAGNUM Mat Set	8,0 m ²	1200 Watt	150 Watt	5,2	44	0,50 x 16,00 m
201805	211805	MAGNUM Mat Set	9,0 m ²	1350 Watt	150 Watt	5,9	39	0,50 x 18,00 m
202005	212005	MAGNUM Mat Set	10,0 m ²	1500 Watt	150 Watt	6,5	35	0,50 x 20,00 m
202405	212405	MAGNUM Mat Set	12,0 m ²	1500 Watt	125 Watt	6,5	35	0,50 x 24,00 m
203005	213005	MAGNUM Mat Set	15,0 m ²	1875 Watt	125 Watt	8,2	28	0,50 x 30,00 m
204010	214010	MAGNUM Mat Set	20,0 m ²	2500 Watt	125 Watt	10,8	21	0,50 x 40,00 m
205010	215010	MAGNUM Mat Set	25,0 m ²	3125 Watt	125 Watt	13,6	17	0,50 x 50,00 m

MAGNUM Mat Underfloor heating mat

The MAGNUM Mat is a unique underfloor heating mat. The system is designed to allow underfloor heating to be installed over an existing tiled floor or on top of a screed that has already been installed. The mat is approximately 4 mm thin and can be included in an adhesive layer without demolition and milling out. The mat is placed almost directly under the surface. This increases the heating rate of the floor which also makes the system suitable for areas with non-permanent occupancy such as bathrooms, hobby rooms, recreation rooms etc.

MAGNUM Mat is available in 22 different sizes from 0,75 to 25m². Because the heating cable on the mat is connected at the end, there is only one side with a power cable, which is invisibly attached through a unique blind connection. This means that there is no need for a return to the thermostat.



Installation in self-levelling compound

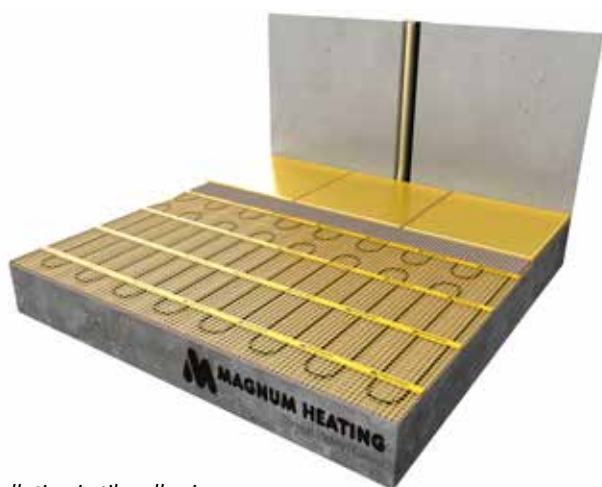
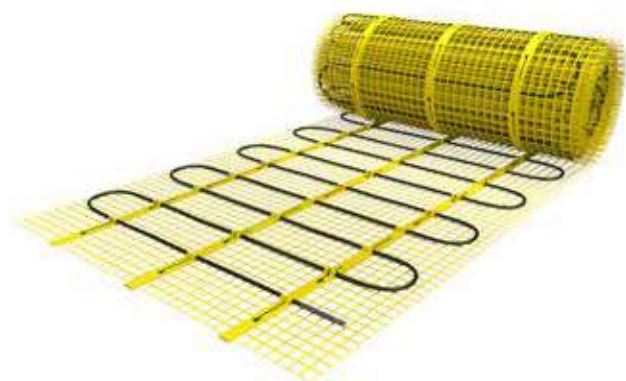

Installation in tile adhesive

Specifications

System type	Electric
System height	4 mm
System width	25 or 50 cm
Min. setting height	10 mm
Installation	Self-levelling / Tile adhesive
Power	125 or 150W/m ²
In wet areas	V
Tiles	V
Wood	V (i.c.w. self-levelling)
(PVC) Laminate	V (i.c.w. self-levelling)
Carpet	V (i.c.w. self-levelling)
Certification	CE, VDE
Warranty	Lifetime*





Unique blind connection between heating and connecting cable

Technical details

- EMC-free, 2-conductor cable attached to fiber optic network
- 2,5 meter three-wire power cable
- Full enclosure by aluminum sheath
- Unique blind connection between heating and connection cable
- Chrome/Nickel resistance wire
- PTFE (Teflon) insulation
- PVC protective sheath
- Cable diameter approx. 4 mm
- Mat width 25 or 50 cm
- Meets current NEN standards for installation in entire wet area

Installation methods

- Directly into tile adhesive
- Self-levelling casting mortars
- In plaster/mortar
- Anhydrite floors
- MAGNUM Mat is not suitable for use in lightweight concrete

Package contents

- Heating mat
- Flexible tube for floor sensor
- Installation instructions & Check/Control card

Warranty

Lifelong* warranty on the electrical operation of the heating mat and 2 years on the thermostat and floor sensor.

*See conditions on: magnumheating.com

Art.nr.	Description	m ²	Power	W per m ²	Amps	Ohm	Dimension
240075	MAGNUM Mat	0,75 m ²	113 Watt	150 Watt	0,6	468	0,25 x 3,00 m
240201	MAGNUM Mat	1,0 m ²	150 Watt	150 Watt	0,7	353	0,50 x 2,00 m
240125	MAGNUM Mat	1,25 m ²	188 Watt	150 Watt	0,8	281	0,25 x 5,00 m
240301	MAGNUM Mat	1,5 m ²	225 Watt	150 Watt	1,0	235	0,50 x 3,00 m
240175	MAGNUM Mat	1,75 m ²	263 Watt	150 Watt	1,1	201	0,25 x 7,00 m
240401	MAGNUM Mat	2,0 m ²	300 Watt	150 Watt	1,3	176	0,50 x 4,00 m
240225	MAGNUM Mat	2,25 m ²	338 Watt	150 Watt	1,5	157	0,25 x 9,00 m
240501	MAGNUM Mat	2,5 m ²	375 Watt	150 Watt	1,6	141	0,50 x 5,00 m
240601	MAGNUM Mat	3,0 m ²	450 Watt	150 Watt	2,0	117	0,50 x 6,00 m
240701	MAGNUM Mat	3,5 m ²	525 Watt	150 Watt	2,3	100	0,50 x 7,00 m
240801	MAGNUM Mat	4,0 m ²	600 Watt	150 Watt	2,6	88	0,50 x 8,00 m
240901	MAGNUM Mat	4,5 m ²	675 Watt	150 Watt	2,9	78	0,50 x 9,00 m
241001	MAGNUM Mat	5,0 m ²	750 Watt	150 Watt	3,3	71	0,50 x 10,00 m
241201	MAGNUM Mat	6,0 m ²	900 Watt	150 Watt	3,9	59	0,50 x 12,00 m
241401	MAGNUM Mat	7,0 m ²	1050 Watt	150 Watt	4,6	50	0,50 x 14,00 m
241601	MAGNUM Mat	8,0 m ²	1200 Watt	150 Watt	5,2	44	0,50 x 16,00 m
241801	MAGNUM Mat	9,0 m ²	1350 Watt	150 Watt	5,9	39	0,50 x 18,00 m
242001	MAGNUM Mat	10,0 m ²	1500 Watt	150 Watt	6,5	35	0,50 x 20,00 m
202421	MAGNUM Mat	12,0 m ²	1500 Watt	125 Watt	6,5	35	0,50 x 24,00 m
203021	MAGNUM Mat	15,0 m ²	1875 Watt	125 Watt	8,2	28	0,50 x 30,00 m
244006	MAGNUM Mat	20,0 m ²	2500 Watt	125 Watt	10,8	21	0,50 x 40,00 m
245006	MAGNUM Mat	25,0 m ²	3125 Watt	125 Watt	13,6	17	0,50 x 50,00 m

MAGNUM Cable 17 Watt (Set) Underfloor heating cable

The MAGNUM Cable is specially designed for installation in cement screeds. The mutual cable distance determines the power per m². This gives you the freedom to install more power (faster reaction, higher temperatures) or less power (for constant or low temperatures).

Because the cable is deformable, installation becomes easy. It can be attached to MAGNUM Isorol and dovetailed sheets through aluminum tape or to concrete mesh with tiwraps. There are also convenient spacer strips available for direct mounting on the floor.

The advanced WiFi thermostat takes into account the necessary warm-up time, so that your floor always has the right temperature at the right time. The absence of radiators on the wall offers optimal freedom in interior design. (If main heating is possible).



Installation with MAGNUM Isorol and tape



Installation on reinforcement mesh with tie wraps

Specifications

System type	Electric
System height	7 mm
System width	Variable
Min. setting height	30 mm
Installation	Screed
Power	115 - 200W/m ²
In wet areas	✓
Tiles	✓
Wood	✓
(PVC) Laminate	✓
Carpet	✓
Certification	CE, VDE
Warranty	Lifetime*

*See conditions on: magnumheating.com



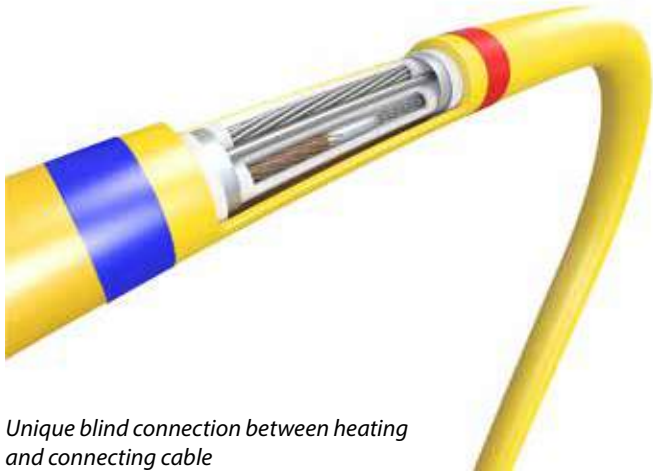

Unique blind connection between heating and connecting cable

Example calculations cable distance

To calculate the correct cable distance, divide the number of square meters of free floor space by the total power of the set. Multiply the result by 17 (= Watts per meter cable). The first two numbers after the comma indicate the cable distance in centimeters.

Some examples of additional heating:

500 Watt cable on 3 m²: (166W/m²)
 (3 m² : 500 Watt) X 17 W/m¹ = 0,102
 Install the cable at 10 cm apart from each other

1000 Watt cable on 7 m²: (142W/m²)
 (7 m² : 1000 Watt) X 17 W/m¹ = 0,119
 Install the cable at 11-12 cm apart from each other

Technical details

- EMC-free, 2-conductor cable
- 2,5 meter three-wire power cable
- Unique blind connection between heating and connection cable
- Full enclosure by aluminum sheath
- Chrome/Nickel resistance wire
- XLPE insulation
- PVC protective sheath
- 17 Watt per meter power, 230 Volt
- Cable diameter approx. 7 mm
- Produced and inspected in accordance with IEC 800 standards
- VDE approved and CE standard within Europe

Installation methods

The cables are available in total capacities from 300 to 3300 Watts, sufficient for surfaces between 2 and 30 m². Because the cable is looped at the end, there is only one side of a power cable, which is invisibly attached through the unique connection. This means that there is no need for a return to the thermostat. MAGNUM Cable is not suitable for use in lightweight concrete.

Package contents

- Heating cable
- MAGNUM Remote Control WiFi thermostat
- Floor sensor
- Mounting tape
- Flexible tube for floor sensor
- Installation instructions

Warranty

Lifelong* warranty on the electrical function of the heating cable and 2 years on the thermostat and floor sensor.

*See conditions on: magnumheating.com

Art.nr. white	Art.nr. black	Cable length	Power	Amps	Ohm
100305	110305	17,6 m	300 Watt	1,3	177
100505	110505	29,4 m	500 Watt	2,2	109
100705	110705	41,2 m	700 Watt	3	76
101005	111005	58,8 m	1000 Watt	4,3	53
101255	111255	73,5 m	1250 Watt	5,5	42
101705	111705	100 m	1700 Watt	7,4	31
102105	112105	123,5 m	2100 Watt	9	25
102605	112605	152,9 m	2600 Watt	11,3	20
102905	112905	170,6 m	2900 Watt	12,8	18
103305	113305	194,1 m	3300 Watt	14,3	16

Art.nr.	Options	Unit
720100	MAGNUM Stabiliser fibres	Bag of 150 gram
720150	MAGNUM Aluminium tape	Roll of 10 m x 5 cm
720310	MAGNUM Spacer strips	10 m
720315	MAGNUM Spacer strips	15 m
720400	MAGNUM Edge strips	Roll of 10 m x 10 cm
720502	MAGNUM Isorol	Roll of 24 m ² (20 x 1,2 m) - 3 mm thick

MAGNUM Cable 17 Watt (Single) Underfloor heating cable

The MAGNUM Cable is specially designed for installation in cement screeds. The mutual cable distance determines the power per m². This gives you the freedom to install more power (faster reaction, higher temperatures) or less power (for constant or low temperatures).

Because the cable is deformable, installation becomes easy. It can be attached to MAGNUM Isorol and dovetailed sheets through aluminum tape or to concrete mesh with tiwraps. There are also convenient spacer strips available for direct mounting on the floor.

The absence of radiators on the wall offers optimal freedom in interior design. (If main heating is possible).

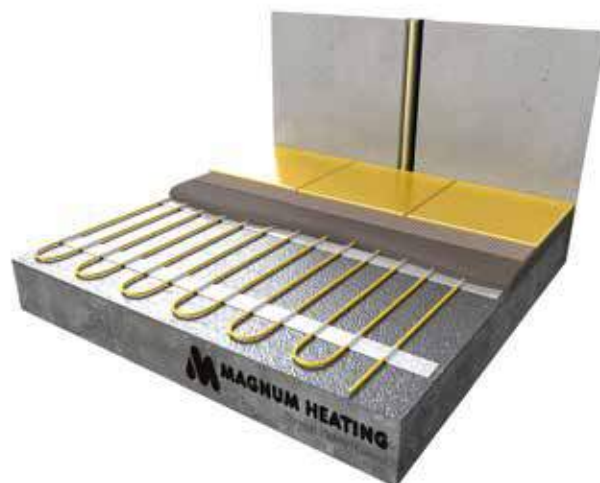

Installation with MAGNUM Isorol and tape



Installation on reinforcement mesh with tie wraps

Specifications

System type	Electric
System height	7 mm
System width	Variable
Min. setting height	30 mm
Installation	Screed
Power	115 - 200W/m ²
In wet areas	✓
Tiles	✓
Wood	✓
(PVC) Laminate	✓
Carpet	✓
Certification	CE, VDE
Warranty	Lifetime*

*See conditions on: magnumheating.com



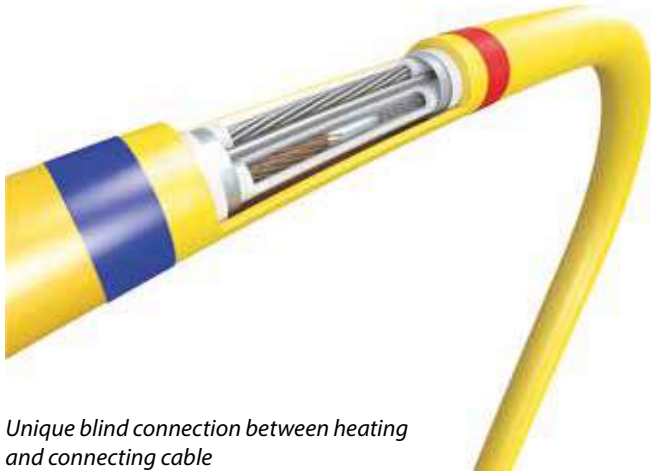

Unique blind connection between heating and connecting cable

Example calculations cable distance

To calculate the correct cable distance, divide the number of square meters of free floor space by the total power of the set. Multiply the result by 17 (= Watts per meter cable). The first two numbers after the comma indicate the cable distance in centimeters.

Some examples of additional heating:

500 Watt cable on 3 m²: (166W/m²)
 (3 m² : 500 Watt) X 17 W/m¹ = 0,102
 Install the cable at 10 cm apart from each other

1000 Watt cable on 7 m²: (142W/m²)
 (7 m² : 1000 Watt) X 17 W/m¹ = 0,119
 Install the cable at 11-12 cm apart from each other

Technical details

- EMC-free, 2-conductor cable
- 2,5 meter three-wire power cable
- Unique blind connection between heating and connection cable
- Full enclosure by aluminum sheath
- Chrome/Nickel resistance wire
- XLPE insulation
- PVC protective sheath
- 17 Watt per meter power, 230 Volt
- Cable diameter approx. 7 mm
- Produced and inspected in accordance with IEC 800 standards
- VDE approved and CE standard within Europe

Installation methods

The cables are available in total capacities from 300 to 3300 Watts, sufficient for surfaces between 2 and 30 m². Because the cable is looped at the end, there is only one side of a power cable, which is invisibly attached through the unique connection. This means that there is no need for a return to the thermostat. MAGNUM Cable is not suitable for use in lightweight concrete.

Package contents

- Heating cable
- Mounting tape
- Flexible tube for floor sensor
- Installation instructions

Warranty

Lifelong* warranty on the electrical function of the heating cable.

*See conditions on: magnumheating.nl

Art.nr.	Description	Cable length	Power	Amps	Ohm
120300	MAGNUM Cable 17	17,6 m	300 Watt	1,3	177
120500	MAGNUM Cable 17	29,4 m	500 Watt	2,2	109
120700	MAGNUM Cable 17	41,2 m	700 Watt	3	76
121000	MAGNUM Cable 17	58,8 m	1000 Watt	4,3	53
121250	MAGNUM Cable 17	73,5 m	1250 Watt	5,5	42
121700	MAGNUM Cable 17	100 m	1700 Watt	7,4	31
122100	MAGNUM Cable 17	123,5 m	2100 Watt	9	25
122600	MAGNUM Cable 17	152,9 m	2600 Watt	11,3	20
122900	MAGNUM Cable 17	170,6 m	2900 Watt	12,8	18
123200	MAGNUM Cable 17	194,1 m	3300 Watt	14,3	16

MAGNUM Cable 10 Watt (Single) Underfloor heating cable

The MAGNUM Cable is specially designed for installation in cement screeds. The mutual cable distance determines the power per m². This gives you the freedom to install more power (faster reaction, higher temperatures) or less power (for constant or low temperatures).

Because the cable is deformable, installation becomes easy. It can be attached to MAGNUM Isorol and dovetailed sheets through aluminum tape or to concrete mesh with tiewraps. There are also convenient spacer strips available for direct mounting on the floor.

The absence of radiators on the wall offers optimal freedom in interior design. (If main heating is possible).



Installation with MAGNUM Isorol and tape



Installation on reinforcement mesh with tie wraps

Specifications

System type	Electric
System height	7 mm
System width	Variable
Min. setting height	30 mm
Installation	Screed
Power	60 - 115 W/m ²
In wet areas	✓
Tiles	✓
Wood	✓
(PVC) Laminate	✓
Carpet	✓
Certification	CE, VDE
Warranty	Lifetime*

*See conditions on: magnumheating.nl





Unique blind connection between heating and connecting cable

Example calculations cable distance

To calculate the correct cable distance, divide the number of square meters of free floor space by the total power of the set. Multiply the result by 10 (= Watts per meter cable). The first two numbers after the comma indicate the cable distance in centimeters.

Some examples of additional heating:

500 Watt cable on 3 m²: (166W/m²)
 (3 m² : 500 Watt) X 10 W/m¹ = 0,06
 Install the cable at 6 cm apart from each other

1000 Watt cable on 7 m²: (142W/m²)
 (7 m² : 1000 Watt) X 10 W/m¹ = 0,07
 Install the cable at 7 cm apart from each other

Technical details

- EMC-free, 2-conductor cable
- 3,5 meter three-wire power cable
- Unique blind connection between heating and connection cable
- Full enclosure by aluminum sheath
- Chrome/Nickel resistance wire
- XLPE insulation
- PVC protective sheath
- 10 Watt per meter power, 230 Volt
- Cable diameter approx. 7 mm
- Produced and inspected in accordance with IEC 800 standards
- VDE approved and CE standard within Europe

Installation methods

The cables are available in total capacities from 100 to 1900 Watts, sufficient for surfaces between 1 and 20 m². Because the cable is looped at the end, there is only one side of a power cable, which is invisibly attached through the unique connection. This means that there is no need for a return to the thermostat. MAGNUM Cable is not suitable for use in lightweight concrete.

Package contents

- Heating cable
- Mounting tape
- Flexible tube for floor sensor
- Installation instructions

Warranty

Lifelong* warranty on the electrical function of the heating cable.

*See conditions on: magnumheating.nl

Art.nr.	Description	Cable length	Power	Amps	Ohm
120107	MAGNUM Cable 10	10 m	100 Watt	0,4	529
120207	MAGNUM Cable 10	20 m	200 Watt	0,9	264
120307	MAGNUM Cable 10	30 m	300 Watt	1,3	176
120407	MAGNUM Cable 10	40 m	400 Watt	1,7	132
120507	MAGNUM Cable 10	50 m	500 Watt	2,2	106
120607	MAGNUM Cable 10	60 m	600 Watt	2,6	88
120807	MAGNUM Cable 10	80 m	800 Watt	3,5	66
121007	MAGNUM Cable 10	100 m	1000 Watt	4,3	53
121207	MAGNUM Cable 10	120 m	1200 Watt	5,2	44
121507	MAGNUM Cable 10	150 m	1500 Watt	6,5	35
121907	MAGNUM Cable 10	190 m	1900 Watt	8,3	28

MAGNUM Foil (Set)

Underfloor heating foil

Wood, parquet and laminate are durable and atmospheric products that are increasingly being used. The demand for a heating system for these floors has led to the development of a new high-tech product. MAGNUM now offers a solution for these "dry" floors. The MAGNUM Foil underfloor heating foil is directly applicable under wood, parquet or laminate. This wafer-thin floor heating system (only 0,3 mm!) is controlled by a WiFi clock thermostat with floor sensor. This ensures very even heating. The floor temperature can be limited to a maximum temperature by means of the floor sensor and thermostat.

The advanced WiFi thermostat takes into account the necessary warm-up time, so that your floor always has the right temperature at the right time. The foil should be installed on 6 mm thin polystyrene insulation plates (MAGNUM Isofoam). These insulation plates provide additional thermal insulation and also have a sound-absorbing effect.

MAGNUM Foil is very easy to cut to size. Safe, comfortable and easy to use: MAGNUM Foil ensures a comfortable living and working environment, even on dry floors!

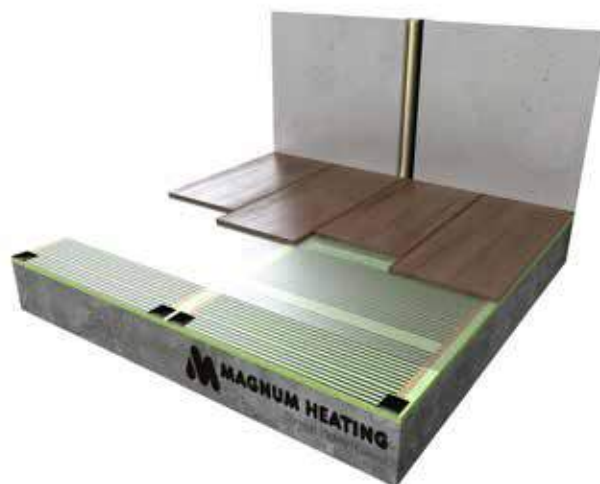

Specifications

System type	Electric
System height	0,3 mm
System width	600 mm
Min. setting height	1 cm
Installation	Dry Construction
Power	120 W/m ²
In wet areas	X
Tiles	X
Wood	V
Laminate	V (no PVC)
Carpet	V
Certification	CE, SEMKO
Warranty	10 years



Technical details

Installation method

MAGNUM Foil is connected to 230V. Installation must therefore be carried out by a qualified electrician. MAGNUM Foil should always be installed with MAGNUM polystyrene insulation plates (MAGNUM Isofoam, 6 mm), and covered with a vapour barrier foil (0,1 mm).

Package content

- Foil on rolls of 5, 10 or 15 m² (120 W/m²)
- MAGNUM Remote Control WiFi thermostat with floor sensor
- Flexible sensor tube
- Insulating tape
- Connection clamps
- Connection wires
- Installation instructions
- Pressure reducers and crimping pliers

To be ordered separately (depending on the number of m²)

- MAGNUM Isofoam, per pack 6 m²
- Vapour barrier foil

Warranty

10 years guarantee on the electrical function of MAGNUM Foil and 2 years on the thermostat and floor sensor.

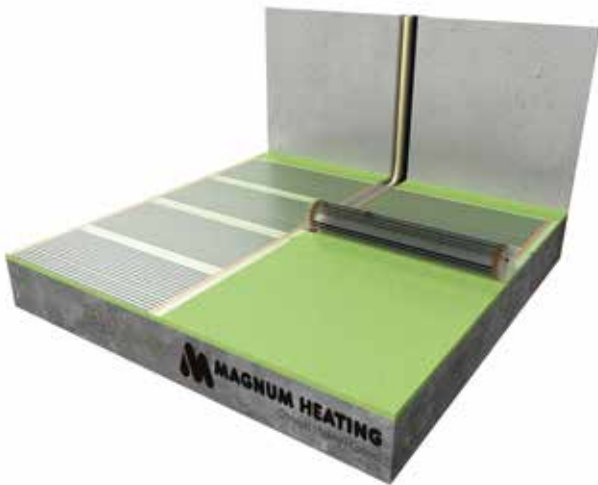

Art.nr. white	Art.nr. black	Description	Dimensions	Power
361005	371005	MAGNUM Foil Set 5 m ² *	0,6 x 8,4 m	600 Watt
361010	371010	MAGNUM Foil Set 10 m ² *	0,6 x 16,8 m	1200 Watt
361015	371015	MAGNUM Foil Set 15 m ² *	0,6 x 25 m	1800 Watt
361110		MAGNUM Foil add-on set 10 m ² **	0,6 x 16,8 m	1200 Watt

Art.nr.	Description	Dimensions	Power m ²
360120	MAGNUM Foil loose per m ² on roll	0,6 x ? m	120 Watt

Art.nr.	Options	Dimensions
720807	MAGNUM Vapour barrier film 12 m ²	4 x 3 m. x 0,1 mm
720810	MAGNUM Foil pressure divider and crimping pliers	
720815	MAGNUM Foil connection set for 10 m ² folie **	
730300	MAGNUM Isofoam PS Insulation 6 m ²	10 à 120 x 50 x 0,6 cm

* Set contains: MAGNUM Foil 120 Watt/m², MAGNUM Remote Control WiFi thermostat with floor sensor, flexible sensor tube, 2 x 15 m connection wire black/blue, necessary crimp connectors, pressure distribution and crimping pliers, vulcanised insulation tape, PP tape, installation instructions.

** Set contains: 2 x 15 m black/blue connection wire, required crimp connectors, vulcanised insulation tape, PP tape, foil 10 m².

MAGNUM HeatBoard (E)

System plates

Wood, parquet and laminate are durable and atmospheric products that are increasingly being used. The demand for a heating system for these floors has led to the development of a new high-tech product.

MAGNUM HeatBoard is directly applicable under floating wood, parquet or laminate floors. This thin floor heating system only 12 mm! (also available as 31 mm plates) Controlled by a digital WiFi thermostat with floor sensor. This ensures very even heating. The floor temperature can be limited to a maximum temperature by means of the floor sensor and thermostat.

The advanced WiFi thermostat calculates the necessary warm-up time, so that your floor always has the right temperature at the right time. This thermostat is not included in the set, must be ordered separately. The insulation plates provide additional thermal insulation and also have a sound-absorbing effect.

MAGNUM HeatBoard is very easy to cut to size. After this, the HeatBoard Cable can simply be clamped in. Approximately 9 m¹ (linear metres) of HeatBoard Cable is required per net/unobstructed area of 1 m². Safe, comfortable and easy to use: MAGNUM HeatBoard ensures a comfortable living and working environment, even on dry floors!

MAGNUM HeatBoard can only be used with hard dry floor systems (laminate, wood and parquet). In the case of so-called soft floor systems (PVC laminate and vinyl), DuoBoard should first be applied between the heating system and the floor covering.



Specifications

System type	Electric
System height	12 mm / 32 mm
System width	594 mm
System length	778 mm
Min. construction height	20 mm
Installation	Floating
Power	60 or 100W/m ²
In wet areas	X
Tiles	X
Wood	V
(PVC) Laminate	V (PVC i.c.w. DuoBoard)
Carpet	V (i.c.w. DuoBoard)
Certification	CE, VDE
Warranty	2 years



Technical details

- Designation according to standard
EPS-EN13163-T2-L2-W2-S2-P2-DLT(1)5-CS(10)150
- Nominal thickness dL 11,5 mm / 30,5 mm
- Coefficient of thermal conductivity 0,036 W/mK DIN V 4108-10
- Thermal resistance 0,32 m²K/W
- Compressive stress 150 kPa (at 10 % compression)
- Load under tension 45 kPa
- Heat resistance < 80°C
- Area of application DEO according to DIN 4108-10
- Fire behaviour Class E according to EN 1350
- Building material class B2 according to DIN 4102
- Material EPS polystyrene hard foam (CFK-free)
- Valid standard EN 13163, DIN V 4108-10

Installation methods

Through a new patented production process, the high-density EPS foam panels are glued to the preformed aluminium plates. This provides the MAGNUM HeatBoard system with contact over the entire floor and, in comparison to similar products, it even provides maximum heat transfer in the curves. The heat transfer from the electric 7 mm MAGNUM HeatBoard Cable is therefore optimally utilised.

With a system height of only 12 mm (also available as 32 mm plates), MAGNUM HeatBoard is the thinnest dry construction system of its kind. The boards have a size of 788 x 594 mm (effective: 589 x 778 mm) and are supplied in a set of 11 plates (5 m²).

Package contents

- 11 HeatBoard E system plates
- 5m² Covering felt
- Safety gloves
- Installation instructions

HeatBoard Cable, thermostat and DuoBoard must be ordered separately.

Warranty

2 years.

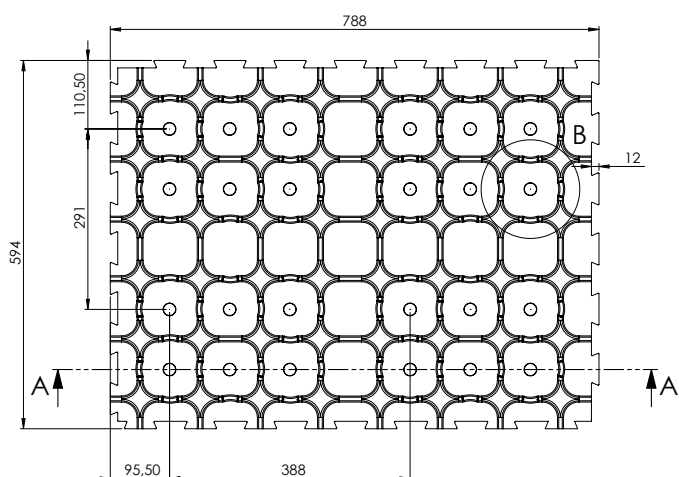

Art.nr.	Description	m ²	Dimensions	Unit
430010	MAGNUM HeatBoard 12 mm	5 m ²	78 x 58 cm	11 plates
430015	MAGNUM HeatBoard 31 mm	5 m ²	78 x 58 cm	11 plates

MAGNUM HeatBoard (E) Cable

Heating cable for HeatBoard system plates

Wood, parquet and laminate are durable and atmospheric products that are increasingly being used. The demand for a heating system for these floors has led to the development of a new high-tech product.

MAGNUM HeatBoard is directly applicable under floating wood, parquet or laminate floors. This thin floor heating system (only 12 mm or 32 mm!) is controlled by a digital WiFi thermostat with floor sensor. This ensures very even heating. The floor temperature can be limited to a maximum temperature by means of the floor sensor and thermostat.

The advanced WiFi thermostat calculates the necessary warm-up time, so that your floor always has the right temperature at the right time. This thermostat is not included in the set, must be ordered separately. The insulation plates provide additional thermal insulation and also have a sound-absorbing effect.

MAGNUM HeatBoard is very easy to cut to size. After this, the HeatBoard Cable can simply be clamped in. Approximately 9 m¹ (linear metres) of HeatBoard Cable is required per net/unobstructed area of 1 m². Safe, comfortable and easy to use: MAGNUM HeatBoard ensures a comfortable living and working environment, even on dry floors!

MAGNUM HeatBoard can only be used with hard dry floor systems (laminate, wood and parquet). In the case of so-called soft floor systems (PVC laminate and vinyl), DuoBoard should first be applied between the heating system and the floor covering.

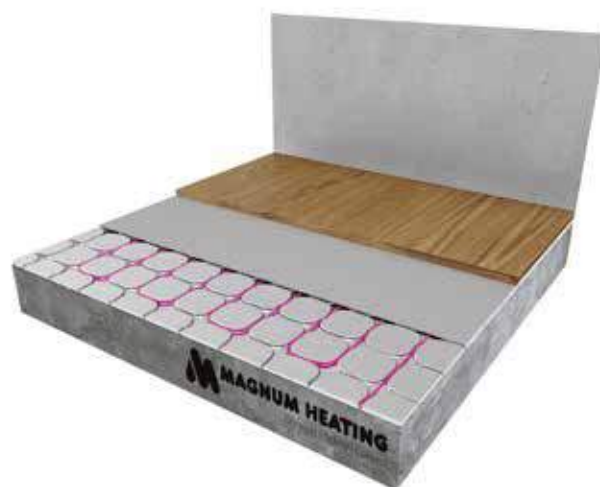

Specifications

System type	Electric
System height	12 mm / 32 mm
System width	from 20 cm
System length	778 mm
Min. construction height	12 mm / 32 mm
Installation	Floating
Power	60 or 100W/m ²
In wet areas	X
Tiles	X
Wood	V
(PVC) Laminate	V (PVC i.c.w. DuoBoard)
Carpet	V (i.c.w. DuoBoard)
Certification	CE, VDE
Warranty	10-year warranty on the electrical operation of the HeatBoard Cable.



Technical details

Installation methods

Through a new patented production process, the high-density EPS foam panels are glued to the preformed aluminium plates. This provides the MAGNUM HeatBoard system with contact over the entire floor and, in comparison to similar products, it even provides maximum heat transfer in the curves. The heat transfer from the electric 7 mm MAGNUM HeatBoard Cable is therefore optimally utilised.

With a system height of only 12 mm, MAGNUM HeatBoard is the thinnest dry construction system of its kind. The boards have a size of 788 x 594 mm (effective: 589 x 778 mm) and are supplied in a set of 11 plates (5 m²).

Package contents

- HeatBoard E Cable
- Mounting tape
- Flexible tube for floor sensor
- Installation instructions
- Profile for end loop

HeatBoard Cable, thermostat and DuoBoard must be ordered separately.

Warranty

10-year warranty on the electrical operation of the HeatBoard Cable.

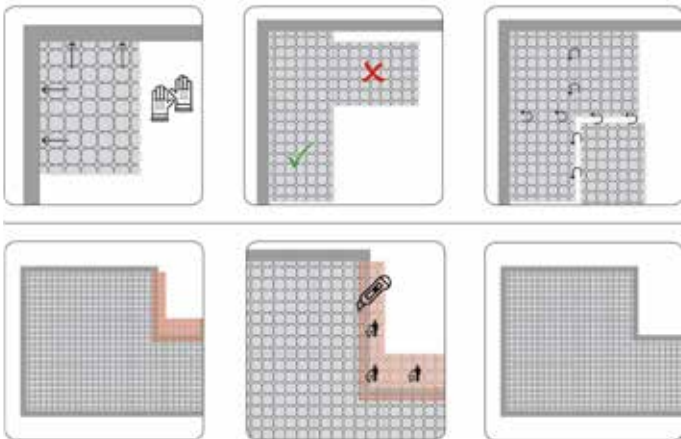

Example of the installation for Heatboard E Cable

Art.nr.	Description (60 Watt/m2)	Cable length	Power
136018	MAGNUM HeatBoard Cable 6	30 m	180 Watt
136030	MAGNUM HeatBoard Cable 6	50 m	300 Watt
136048	MAGNUM HeatBoard Cable 6	80 m	480 Watt
136060	MAGNUM HeatBoard Cable 6	100 m	600 Watt
136072	MAGNUM HeatBoard Cable 6	120 m	720 Watt
136090	MAGNUM HeatBoard Cable 6	150 m	900 Watt
136140	MAGNUM HeatBoard Cable 6	190 m	1140 Watt

Art.nr.	Description (100 Watt/m2)	Cable length	Power
131030	MAGNUM HeatBoard Cable 10	30 m	300 Watt
131050	MAGNUM HeatBoard Cable 10	50 m	500 Watt
131080	MAGNUM HeatBoard Cable 10	80 m	800 Watt
131100	MAGNUM HeatBoard Cable 10	100 m	1000 Watt
131120	MAGNUM HeatBoard Cable 10	120 m	1200 Watt
131150	MAGNUM HeatBoard Cable 10	150 m	1500 Watt
131190	MAGNUM HeatBoard Cable 10	190 m	1900 Watt

MAGNUM Sol Ceiling heaters

MAGNUM Sol ceiling heaters can be installed “invisibly” in a suspended ceiling and offer maximum freedom in interior design or showroom arrangement for any office, showroom or shop. However, with the integrated suspension bracket, the panels can also be attached directly to any ceiling.

The ceiling heaters heat everything and everyone within their radiant range in the same way that the sun heats the earth. This with a very short heating time. Ideal for rooms that are not continuously occupied, need to be brought up to temperature in a short time and have little wall space available.

The MAGNUM Sol heating panel is not suitable for installation and use in wet rooms. Only MAGNUM Sol Premium should be used for this application.

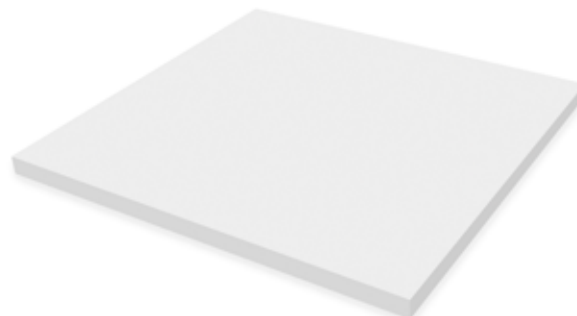

Specifications

System type	Electric
System height	30 mm
System width	590 mm
Min. setting height	2,2 m
Installation	Ceiling
Power	300 or 600 Watt
In wet areas	X
Type of heating	Infrared
System ceiling	V
Ceiling mounting	V
Certification	Kema
Warranty	2 years





MAGNUM Sol Type 300



MAGNUM Sol Type 600

Technical details

- Available 300 and 600 Watt
- Connection voltage 230V/50Hz
- Class IP44
- Color RAL 9016

Installation methods

MAGNUM Sol ceiling heating panels are easy to install in every suspended ceiling or to mount directly on the ceiling via the integrated suspension system. Each panel is equipped with its own suspension system.

The panels can be thermostatically or modulatively controlled, which minimises energy loss. They can be controlled through a simple on/off thermostat or a wireless RF thermostat.

Package content

- Suspension bracket
- 0,5 metre connection cable
- Installation instructions

Warranty

MAGNUM Sol has a 2 year guarantee on the electrical function.

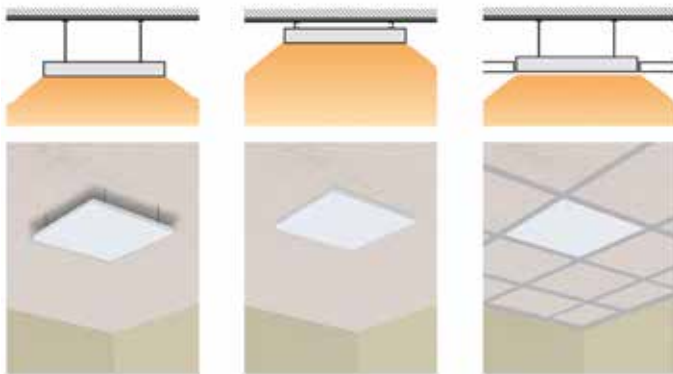

Several installation options

Art.nr.	Description	Type	Power	Dimensions
600331	MAGNUM Sol	300	300 Watt	590 x 590 x 30 mm
600661	MAGNUM Sol	600	600 Watt	1190 x 590 x 30 mm

Art.nr.	Description
825100	MAGNUM Remote Control WiFi thermostat (Polar White - RAL 9010) incl. floor sensor
825101	MAGNUM Remote Control WiFi thermostat (Graphite black - RAL 9011) incl. floor sensor
827000	MAGNUM Standard Control on/off concealed thermostat

Art.nr.	Options
838000	MAGNUM RF Basic - thermostat incl. RF receiver (8 Amps)
838001	MAGNUM RF Advanced - digital clock thermostat incl. RF receiver (8 Amps)
838002	MAGNUM RF Receiver - additional receiver for RF thermostats (8 Amps)

MAGNUM Sol Premium Ceiling heaters

MAGNUM Sol Premium ceiling heaters can be installed in a suspended ceiling and, thanks to the integrated suspension bracket, they can also be directly attached to any ceiling. This panel can be used as main heating or as additional heating in a bathroom. There are 2 outputs available: 300W and 750W. These heating panels produce exclusively radiant heat. The high intensity of the infrared heat waves results in an optimal feeling of comfort after only a short time.

The ceiling heaters heat everything and everyone within the radiation range, just like the sun heats the earth. This with a very short warm-up time. It is therefore ideal for rooms that are not continuously occupied, need to be brought up to temperature in a short time and have little wall space available.

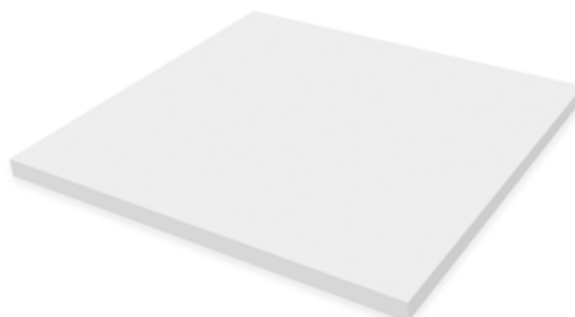

Specifications

System type	Electric
System height	30 mm
System width	592 mm
Min. setting height	2,25 m
Installation	Ceiling
Power	300 or 750 Watt
In wet areas	V
Type of heating	Infrared
System ceiling	V
Ceiling mounting	V
Certification	Kema, CE
Warranty	2 years





MAGNUM Sol Premium Type 300

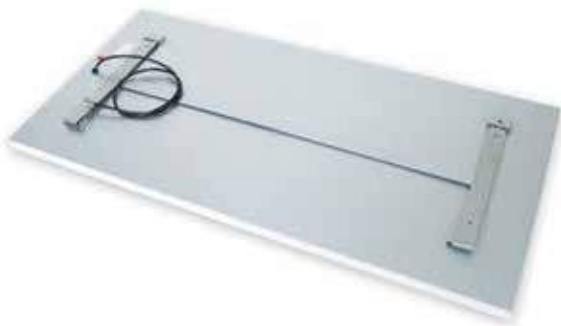

MAGNUM Sol Premium Type 750

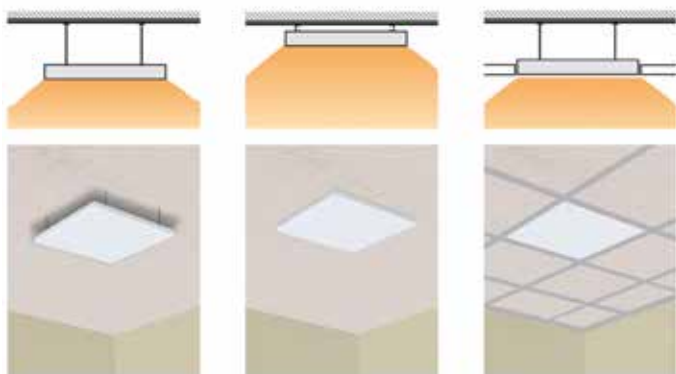

Several installation options

Technical details

- Available in 300 and 750 Watt
- Connection voltage 230V/50Hz
- Class IP54
- Colour RAL 9010

Installation methods

MAGNUM Sol Premium ceiling heating panels are easy to install in any suspended ceiling or to attach directly to the ceiling using the integrated suspension system. Each panel is equipped with its own suspension system.

The panels can be thermostatically or modulatively controlled, which minimises energy loss. They can be controlled through a simple on/off thermostat or a wireless thermostat.

Package content

- Suspension bracket
- 0,5 metre connection cable
- Installation instructions

Warranty

2 year warranty on the electrical function.

Art.nr.	Description	Type	Power	Dimensions
610331	MAGNUM Sol Premium	300	300 Watt	592 x 592 x 30 mm
610751	MAGNUM Sol Premium	750	750 Watt	1192 x 592 x 30 mm

Art.nr.	Options
825100	MAGNUM Remote Control WiFi thermostat (Polar White - RAL 9010) incl. floor sensor
825101	MAGNUM Remote Control WiFi thermostat (Graphite black - RAL 9011) incl. floor sensor
827000	MAGNUM Standard Control on/off concealed thermostat

* RF thermostats are not suitable for use in bathrooms, for this you can connect a MAGNUM Remote Control, Z-Wave or S-Control.

MAGNUM Look Mirror heating

MAGNUM Look mirror heating always provides a clear view when shaving, cutting hair and applying make-up. No more wiping with a towel to see yourself in the mirror after showering or using hot water.

MAGNUM Look is connected and easily switched through the light switch and prevents condensation in no time. It also prevents the unpleasant towel marks that remain after removing condensation. Connecting directly to the mains, through the light switch in the bathroom, avoids unnecessary waste of energy.

MAGNUM Look mirror heating is a self-adhesive heating foil element that can be applied directly to the back of the mirror. The elements are double insulated and can therefore also be used in humid rooms.

The capacity achieves a fast heating-up time of approx. 5 to 8 minutes. In that short time, the mirror is already brought to a temperature of approx. 40°C and condensation is prevented. The maximum achievable mirror temperature is limited to approx. 50°C. This makes the product absolutely safe to touch.



Specifications

System type	Electric
System height	1 mm
System width	Various sizes
Min. setting height	1 mm
Installation	Self-adhesive element
Power	50 - 150 Watt
In wet areas	V
Type of heating	Infraric
System ceiling	V
Ceiling mounting	V
Regulation	Light switch (no dimmer)
Certification	CE
Warranty	2 years





MAGNUM Look circular

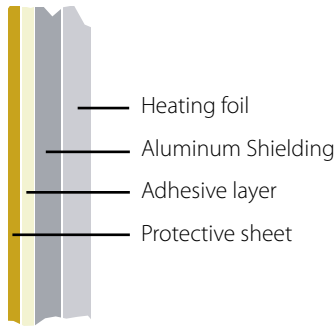

Technical details

- Thickness 1 mm
- Voltage 230 Volt
- Connection 2-core, double insulated
- Class IP-34, class 2
- Temperatures 40°C to 50°C
(depending on ambient temperature)

Installation methods

The mirror must not be damaged (e.g. broken off pieces of the edge, cut to size by hand, etc.) because of possible cracking due to tension differences during heating. For fixing, you can simply use the self-adhesive backing. This should be applied directly to the back of the mirror.

ATTENTION: The film has a very high adhesive strength, therefore it is permanently attached.

Package content

- Heating foil with self-adhesive backing
- ±1 meter connection cable
- Installation instruction

Warranty

2 year warranty on the electrical function.

Art.nr.	Description	Power	Dimensions
310035	MAGNUM Look Mirror heating	50 Watt	Round 35 cm
310029	MAGNUM Look Mirror heating	27 Watt	29 x 29 cm
310050	MAGNUM Look Mirror heating	50 Watt	36 x 50 cm
310058	MAGNUM Look Mirror heating	50 Watt	40 x 58 cm
310055	MAGNUM Look Mirror heating	70 Watt	50 x 58 cm
310075	MAGNUM Look Mirror heating	100 Watt	57 x 75 cm
310085	MAGNUM Look Mirror heating	120 Watt	58 x 85 cm
310110	MAGNUM Look Mirror heating	150 Watt	57 x 110 cm

MAGNUM IsoRol Insulation

MAGNUM Isorol is an expanded polystyrene foam covered on one side with a metallized PET film 12 μ . Can be used as an underlay for MAGNUM Cable (take into account sufficient structural strength for floating floors). The base floor must be free of dust and grease, smooth and dry. Unevenness of more than 2 mm must be levelled. Place the underlay with the PET layer facing upwards. The seams should be sealed with a special aluminium / polyester tape. This tape has to be ordered separately.



Technical details

- Immune to humidity and mould
- Has excellent reflective and moisture insulating properties (thanks to the metallized PET film)
- Easy to install and to cut
- Very high mechanical strength
- 100% CFK-free material
- Suitable for MAGNUM Cable
- Suitable for laminate floors up to 9 mm

Density	Min. 15kg/m ³
EPS foam	Fire resistant quality
Temperature range	30°C tot +70°C
Insulation value	0,036 W/mK
Short term compression strength	With 10% distortion 60kPa
Thermal shape stability	
transient	100°C
longer term	at -5000 Pa 85°C
	at -20000 Pa 75-80°C

Installation methods

- The floor must be clean, dry and free of uneven spots.
- Before application, remove any irregularities of the subfloor > 2mm.
- Roll out the first strip with the silver side up and lay the next strip side by side with the first.
- Unfold the overlap strip and lay it over the next strip, the edges should be connected by using the integrated adhesive tape.
- After laying the floor, cut off the excess material at the ends.

Package content

- MAGNUM IsoRol 24m²
- Productsheet

Specifications

Thickness	3 mm
Compressive strength	CS 1: 10 kPa < CS ≤ 50 kPa according to EN 826 + A.3.7
Impact sound reduction	20 db(with laminate) according to DIN EN ISO 140-8/717-2
Footstep noise reduction	19 % according to IHD W431
Temp. resistance	40°C: +/- 0,09 m2K/W according to DIN EN ISO 12667
Tensile strength	CC2: 25 kPa < CC ≤ 50 kPa according to EN 1606 + A.3.8
Water vapour diffusion resistance	> 100 m according to DIN 52615 / DIN EN 12086
Fire resistance	E according to DIN EN 13501-1:2007 +A1 2013
Warranty	2 years



Art.nr.	Description	m ²	Unit	Dimensions	Thickness
720502	MAGNUM Isorol	24 m ²	Roll	20 x 1,2 m	3 mm

MAGNUM Edge insulation

Positioning systems and accessories

Edge insulation

Edge insulation should be applied when floor heating is used. This form of insulation prevents unwanted heat loss and absorbs the expansion and contraction of the floor. The edge insulation will also ensure that no cold bridges are formed.



Specifications

Roll length	25 m
Foam thickness	8 mm ± 1 mm
Foam width	150 mm ± 5 mm
Material	PE - foam
Density	18 kg/m ³ ± 5 kg/m ³
Packaging	In sturdy plastic foil
Color	Grey
Fire class	EN 13501-1:2010
Application	Conforms to all types of underfloor heating systems
Warranty	2 years
Inspection	CE



Art.nr.	Description	Dimensions
W90111	Edge insulation	25 m x 15 cm x 8 mm with flap

MAGNUM IsoFoam Insulation

MAGNUM IsoFoam is a 6 mm thin floor insulation manufactured from fully recycled materials. The structure of the Isofoam consists of small closed cells that have an excellent insulating effect. This special structure ensures that it does not conduct heat to the bottom, so that all the heat generated by MAGNUM Foil is directed towards the floor surface.



Technical details

Installation methods

- Lightweight
- Optimal noise reduction
- Excellent heat insulation
- Levels out small irregularities in the floor
- Easy to install and to cut
- Only 6 mm thin
- Suitable for MAGNUM Foil

Package content

- MAGNUM IsoFoam 6m²
- Product sheet

Warranty

2 year warranty.

Specifications

Thickness	6 mm
Density	28 kg/m ³
Heat resistance	0,19 m ² K/W
Heat transfer coefficient	0,029 – 0,034 W/(mK)
Water absorption after 24 hours	≤ 1 %
Water absorption after 24 days	≤ 2 %
Compressive strength	≥ 10 kPa PN-EN ISO 826:2013
Dynamic load resistance	≥ 2 kPa
Impact sound reduction	18 dB EN ISO 10140
Footstep noise reduction	9 % EN 16205
Warranty	2 years



Art.nr.	Description	Unit	Dimensions	Thickness
730300	MAGNUM IsoFoam PS Insulation	6 m ²	10 plates of 120 x 50 cm	6 mm

MAGNUM IsoPlate

Insulation

MAGNUM IsoPlate offers the possibility of additional floor insulation where only very limited construction height is available. Due to the pressure-resistant properties of the insulation plates, an underfloor heating system (MAGNUM Mat) and a tiled floor can be directly glued on. MAGNUM IsoPlate increases the insulating properties of the subfloor and thereby increases the efficiency and response time of the underfloor heating system used. These insulating properties result in lower energy consumption.



Technical details

Installation methods

- Moisture and rot resistant
- Fire resistant
- Very low moisture absorption
- Suitable for MAGNUM Mat
- Suitable for MAGNUM Slim Fit
- Fire resistance DIN4102 material class B1
- Water resistance Water absorption >0,5% after 28 days under water according to DIN53 421
- Temp. resistance -30°C tot +70°C
- Insulation value 0,035 W/mK according to DIN4108
- Compressive strength > 0,20 N/mm² according to DIN 52 615

Package content

- MAGNUM IsoPlate (5 x at 10 mm / 8 x at 6 mm)
- Fixing material
- Tape

Warranty

2 year warranty.

Specifications

Insulation value	0,035 W/mK in accordance with DIN 4108
Compressive strength	0,20 N/mm ² according to DIN 52 615
Temp. resistance	-30°C tot +70°C
Water resistance	0,5% after 28 days under water, according to DIN53 421
Fire resistance	DIN 4102 material class B1



Art.nr.	Description	Material	Unit	Dimensions	Thickness
630112	MAGNUM IsoPlate	Polystyrene hardfoam	3 m ²	5 plates of 60 x 100 cm	10 mm
630113	MAGNUM IsoPlate	Polystyrene hardfoam	4,8 m ²	8 plates of 60 x 100 cm	6 mm

MAGNUM DuoBoard

Stable base for soft floor finishes (carpet, PVC, rubber, linoleum, vinyl, cork etc.) over dry floor heating systems.

This solution is designed for installation on underfloor heating to provide a smooth, stable and level base for laying carpet, linoleum and the like. DuoBoard consists of two layers of MDF boards (each with dimensions of 1200 x 600 x 3 mm): Base board and Top board.

DuoBoards are characterised by a low construction height, great durability and high thermal conductivity. Before installation, the product should be stored for at least 48 hours at a temperature of not less than 18°C and a relative humidity of not more than 60% in the room where the DuoBoard system will be used. The base plates must also be properly cleaned of dust and dirt before installation. The base plate can only be glued once.

The surface of the underfloor heating layer must be stable, level and clean.



Base Board, 3 mm, left and Top Board 4 mm, right.

Example of a laying plan:

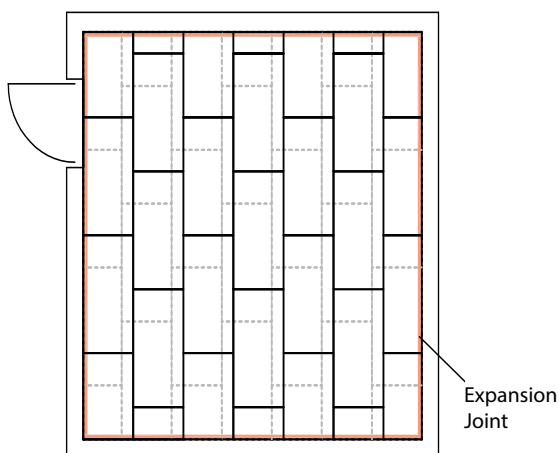

Cross-section of the floor structure:

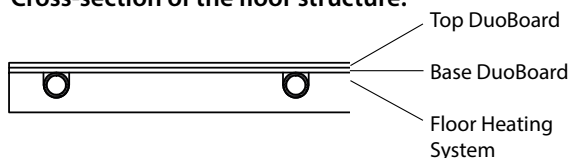

Specifications

Density	860 (kg/m)
Thermal conductivity λ	0,192 (W/mK)
Heat resistance R	0,037 (m K/W)
Bending strength according to EN 310	≥ 23 (N/mm)
Tensile strength according to EN 319	≥ 65 (N/mm)
Swelling after 24 hours according to EN 317	≤ 60 (%)
Formaldehyde content E1 class according to PN-EN 120	max. 8 (mg/100g)
Warranty	2 years
Inspection	CE



Art.nr.	Description	m ²	Material	Dimensions
430030	MAGNUM DuoBoard 2 x 4	2,88 m ²	MDF boards	1200 x 600 x 3 mm Base Board Top Board 4 mm

MAGNUM Contact adhesive

Multi-purpose glue spray

This contact adhesive was specially developed to bond various MAGNUM laying systems to flat, dry, dust- and grease-free dimensionally stable subfloors such as, for example, sand cement and concrete. Apply the contact adhesive from the spray can effervescently at various points. The adhesive cross-links around the fixing point and thus bonds the Plastic or EPS systems to the substrate. The average drying time is 45-60 minutes. 1 spray can is enough for approximately 5 m².

Instructions for use

The processing temperature is at least 15°C. The surfaces to be bonded should be dry, clean, grease- and dust-free.

Spray an even layer of glue on both surfaces, making sure it is applied evenly to the edges.

The adhesive is dry after about 1-2 min. Roll or press the materials firmly. Correcting is no longer possible.

Cleaning: adhesive residues can be removed with a suitable cleaner.



MAGNUM Contact adhesive 500 ml

Specifications

Contents per can	500 ml
Suitable systems	MAGNUM Mat, SlimFit, DryFloor, HeatBoard E&W, Tacker plate and Stud plate.
Drying time	45 - 60 minutes
Max surface area per aerosol can	5 m ²
Substrate	Mould-proof, flat, dry, grease- and dust-free
Processing	See user manual

Art. no.	Description	Content
W61027	MAGNUM Contact adhesive	500 ml

MAGNUM Remote Control (MRC)

Smart WiFi thermostat

The MAGNUM Remote Control smart WiFi thermostat (MRC) is the most advanced on the market. When developing this new thermostat, our first priority was ease of use. The MRC thermostat therefore has a completely new user interface that can be operated easily and intuitively from the screen and an app.

Smartly arranged

The MRC calculates the heating time itself. You only have to enter the periods in which you want your floor to be warm. It gradually learns the ideal heating time for the floor and automatically adjusts its programme accordingly. So if you set the floor to 23°C at 7 in the morning, the thermostat does the rest.

3 in 1 operation

The MAGNUM MRC can be operated using the touch screen on the thermostat. In addition, you can remotely control the thermostat from anywhere at any time with your smartphone through the app (iOS and Android). It also works with the voice assistants of Google and Amazon. With this, you can turn the thermostat up or down or ask what the current temperature of your floor is. Useful, for example, if you are in the car and cannot use your mobile manually.



Wooden floors

The MAGNUM MRC also has a wood floor function where the temperature is limited to 28°C. This makes the MAGNUM MRC the perfect and safe solution for any electric heating system.

Supplied as standard with each set

The MAGNUM Remote Control (Polar White - RAL 9010) comes standard with every MAGNUM Mat, Cable and Foil underfloor heating set, including a built-in air sensor and floor sensor (12K). Thanks to its clever design, this concealed thermostat fits virtually every single and multiple switch material. White and black can be supplied as a set.



Polar white - RAL 9010

Specifications

Type	Smart WiFi thermostat
Suitable for	Electrical systems
Controls	Full touch screen
Sensors	Room and floor sensor (12K)
Voltage	230V – 50/60Hz
Maximum load	16A / 230V
Temperature range	+5 / +40°C
Housing	IP21

Functions

WiFi	✓ 2.4Ghz
App	✓ iOS & Android
Voice assistant	Google assistant and Amazon Alexa
Programmable	up to 3 periods per day
Intelligence	✓
Wooden floor	✓ < 28°C
Open window	✓
Slow start	✓





Graphite black - RAL 9011

Technical details

- Voltage 230V - 50/60 Hz
- Max. load 16A / 230V
- Temp. range +5 / +40°C
- Housing IP21
- Floor sensor (12K) and built-in room sensor
- WiFi (2.4 Ghz)
- Full touch screen and colour display
- Magnetic connection
- Smart user interface
- Open window function
- Up to 3 periods per day can be set
- Night vision
- App for iOS and Android
- Works with Amazon Alexa and Google Assistant
- Automatic start-up menu
- Intelligent and self-learning
- Slow start-up function
- Wood floor function (limited 28°C)
- Backup function
- Automatic summer & winter time
- Multilingual programming

Installation method

Suitable for electric heating systems.

Package content

- MRC Thermostat
- Installation instructions
- Manual
- Floor sensor (12k)

Warranty

2 year guarantee on the electrical operation and floor sensor.

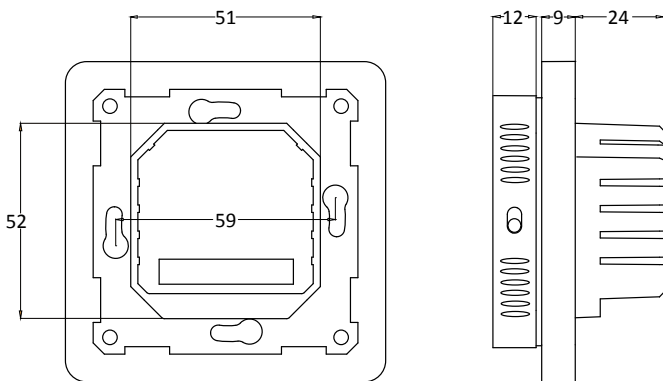

Thermostat dimensions

Art.nr.	Description	Color code
825100	MAGNUM Remote Control WiFi thermostat incl. floor sensor	Polar white - RAL 9010
825101	MAGNUM Remote Control WiFi thermostat incl. floor sensor	Graphite black - RAL 9011

MAGNUM Z-Wave Control

Electronic thermostat

This Z-Wave thermostat is an electronic thermostat for installation in a standard wall box. The thermostat has a built-in Z-Wave 500 chip which can be connected to home automation systems such as Fibaro, Sensio, Vera, Zipato. The display shows the floor or ambient temperature.

The thermostat is equipped with touch-sensitive buttons. By lightly pressing the buttons, the display will show the set value. The Z-Wave thermostat is equipped with a single-pole switch. It can be used with two external temperature sensors.

What is Z-Wave?

Z-Wave is the name of a wireless signal for controlling devices in your home, also known as home automation. In other words, it allows you to program your home (e.g. when does the thermostat go on/off and what temperature). And you can control all this remotely using your tablet or smartphone.

Compatible systems

The MAGNUM Z-Wave thermostat works with systems such as Fibaro, Vera, Zipato and Sensio.



MAGNUM Z-Wave Polar white - RAL 9010

Specifications

Type	Smart Z-Wave thermostat
Suitable for	Electrical systems
Control	Touch buttons
Sensors	Room and floor sensor (10K)
Voltage	230V – 50/60Hz
Maximum load	16 A / 230V
Temperature range	+5 / +40°C
Housing	IP21

Functions

WiFi	V
App	X through Z-Wave system
Voice assistant	X
Programmable	V
Intelligentie	X
Wooden floor	V
Open window	X
Slow start	X

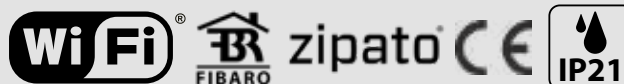



MAGNUM Z-Wave all black (optional)

Technical details

- Voltage 230 Volt - 50/60 Hz
- Max. load 16A / 230 V
- Temperature range +5 / +40°C
- Class IP21
- Color Polar white (RAL 9010)
Black (RAL 9011)
- Certification CE
- Power consumption 1,5W
- Min/Max operating temp. 5°C tot 40°C
- Temp.interval floor sensor 5°C tot 40°C
- Temp.interval room sensor 5°C tot 40°C
- Smartstart Adding the thermostat to a Z-wave network by scanning a supplied QR code
- Power metering Reading consumption
- Over The Air Update (OTA) The ability to update the Z-wave wirelessly
- Room and floor sensor
- Temperature limiter
- Power controller
- Built-in Z-Wave chip 500 series
- Weekly programme through gateway
- 7-segment LCD display
- Can be used in combination with various NTC sensors
- Lock mode / child lock
- Backlight
- Calibration possibility
- 8 scenarios
- Works with Fibaro, Sensio, Vera and Zipato systems

Installation method

Suitable for electric heating systems.

Package content

- Z-Wave Thermostat
- Installation instructions
- Floor sensor (10K)

Warranty

2 year guarantee on the electrical operation and floor sensor.

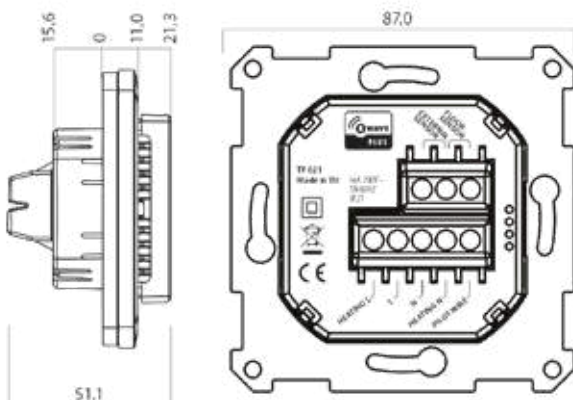

MAGNUM Z-wave measurements

Art.nr.	Description	Color code
825861	MAGNUM Z-wave Control for Fibaro, Sensio, Vera and Zipato systems	Polar white - RAL 9010
825860	MAGNUM Z-wave Control for Fibaro, Sensio, Vera and Zipato systems	Graphite black - RAL 9011

F32 WiFi Thermostat

Smart WiFi thermostat

The stylish F32 Wi-Fi thermostat is a programmable thermostat designed to control electric underfloor heating systems. Install the App on your smart device to control the heating system remotely with this Wi-Fi thermostat.

An App is available in the Apple App Store and on Google Play. Within the App, you can program and adjust settings. Extra thermostats can easily be added to control different rooms.

Besides the Wi-Fi connection, this thermostat can also work as a simple stand-alone unit (select temperature and mode). It is fully programmable within the App. Therefore it is suitable for easy use and also perfect for hotels and holiday homes with the addition of a pilot wire.

An open window function is also included. If the temperature suddenly drops, the thermostat automatically switches off, preventing additional electricity costs.



Magnetic connection



Specifications

Type	Smart WiFi thermostat
Suitable for	Electrical systems
Controls	Touchscreen
Sensors	Room and floor sensor (12K)
Voltage	230V – 50/60Hz
Maximum load	16A /230V
Temperature range	+5°C / +40°C
Housing	IP21

Functions

WiFi	✓ 2.4Ghz
App	✓ iOS & Android
Voice assistant	Google assistant and Amazon Alexa
Programmable	up to 3 periods per day
Intelligence	✓
Wooden floor	✓ < 28°C
Open window	✓
Slow start	✓
Pilot Wire	✓



F32 WiFi Thermostat

Smart WiFi thermostat

The stylish F32 Wi-Fi thermostat is a programmable thermostat designed to control electric underfloor heating systems. Install the App on your smart device to control the heating system remotely with this Wi-Fi thermostat.

An App is available in the Apple App Store and on Google Play. Within the App, you can program and adjust settings. Extra thermostats can easily be added to control different rooms.

Besides the Wi-Fi connection, this thermostat can also work as a simple stand-alone unit (select temperature and mode). It is fully programmable within the App. Therefore it is suitable for easy use and also perfect for hotels and holiday homes with the addition of a pilot wire.

An open window function is also included. If the temperature suddenly drops, the thermostat automatically switches off, preventing additional electricity costs.



Magnetic connection



Specifications

Type	Smart WiFi thermostat
Suitable for	Electrical systems
Controls	Touchscreen
Sensors	Room and floor sensor (12K)
Voltage	230V – 50/60Hz
Maximum load	16A /230V
Temperature range	+5°C / +40°C
Housing	IP21

Functions

WiFi	✓ 2.4Ghz
App	✓ iOS & Android
Voice assistant	Google assistant and Amazon Alexa
Programmable	up to 3 periods per day
Intelligence	✓
Wooden floor	✓ < 28°C
Open window	✓
Slow start	✓
Pilot Wire	✓



MAGNUM Standard Control Thermostat

In some situations, a digital control is less necessary, and a simple on/off control is preferred. Especially in industrial applications or if continuous heating is required. For this purpose MAGNUM has developed the Standard Control: a simple on/off thermostat with temperature control that excels in simplicity and ease of use.

Technical details

- Voltage 230 Volt - 50/60 Hz
- Max. load 16A / 230 V
- Temperature range +5 / +40°C
- Housing IP21
- Color Polar white (RAL 9010)
- Certification CE
- On/off thermostat with temperature control
- Includes floor sensor
- Built-in room sensor and floor limit sensor
- Multi-frame adapter system for: Gira, Jung, Elko, Merten, Busch Jager etc.

Installation method

Suitable for electric heating systems.

Package content

- Thermostat
- Installation instructions
- Floor sensor
- two frames

Warranty

2 year guarantee on the electrical operation and floor sensor.



Specifications

Type	On/off thermostat
Suitable for	Electrical systems
Controls	Physical buttons
Sensors	Room and floor sensor (12K)
Voltage	230V – 50/60Hz
Maximum load	16A / 230V
Temperature range	+5 / +40°C
Housing	IP21



Art.nr.	Description	Color code
827000	MAGNUM Standard Control On/Off Thermostat	Polar white - RAL 9010

MAGNUM Sol Ceiling heaters

MAGNUM Sol ceiling heaters can be installed “invisibly” in a suspended ceiling and offer maximum freedom in interior design or showroom arrangement for any office, showroom or shop. However, with the integrated suspension bracket, the panels can also be attached directly to any ceiling.

The ceiling heaters heat everything and everyone within their radiant range in the same way that the sun heats the earth. This with a very short heating time. Ideal for rooms that are not continuously occupied, need to be brought up to temperature in a short time and have little wall space available.

The MAGNUM Sol heating panel is not suitable for installation and use in wet rooms. Only MAGNUM Sol Premium should be used for this application.



Specifications

System type	Electric
System height	30 mm
System width	590 mm
Min. setting height	2,2 m
Installation	Ceiling
Power	300 or 600 Watt
In wet areas	X
Type of heating	Infrared
System ceiling	V
Ceiling mounting	V
Certification	Kema, CE
Warranty	2 years





MAGNUM Sol Type 300

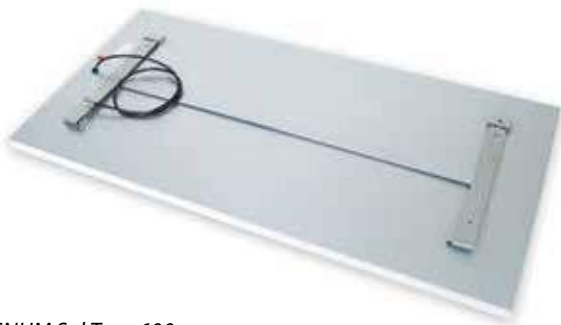

MAGNUM Sol Type 600

Technical details

- Available 300 and 600 Watt
- Connection voltage 230V/50Hz
- Class IP44
- Color RAL 9016

Installation methods

MAGNUM Sol ceiling heating panels are easy to install in every suspended ceiling or to mount directly on the ceiling via the integrated suspension system. Each panel is equipped with its own suspension system.

The panels can be thermostatically or modulatively controlled, which minimises energy loss. They can be controlled through a simple on/off thermostat or a wireless RF thermostat.

Package content

- Suspension bracket
- 0,5 metre connection cable
- Installation instructions

Warranty

MAGNUM Sol has a 2 year guarantee on the electrical function.

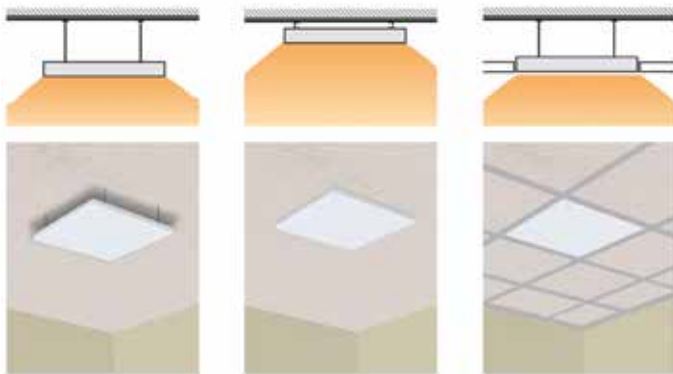

Several installation options

Art.nr.	Description	Type	Power	Dimensions
600331	MAGNUM Sol	300	300 Watt	590 x 590 x 30 mm
600661	MAGNUM Sol	600	600 Watt	1190 x 590 x 30 mm

Art.nr.	Description
825100	MAGNUM Remote Control WiFi thermostat (Polar White - RAL 9010) incl. floor sensor
825101	MAGNUM Remote Control WiFi thermostat (Graphite black - RAL 9011) incl. floor sensor
827000	MAGNUM Standard Control on/off concealed thermostat

Art.nr.	Options
838000	MAGNUM RF Basic - thermostat incl. RF receiver (8 Amps)
838001	MAGNUM RF Advanced - digital clock thermostat incl. RF receiver (8 Amps)
838002	MAGNUM RF Receiver - additional receiver for RF thermostats (8 Amps)

MAGNUM SlimFit 12 Underfloor heating system

With an installation height from 12 mm, MAGNUM Slimfit is one of the lowest systems of its kind. Can be used for both wall and floor heating.

This system consists of plastic mats (tiles) that are simply clicked together. An underfloor heating tube of 12 mm is clamped in the mats with the same ease. The total height of only 14 mm makes this system ideal for renovation projects. Installation is possible both on the floor and in the wall.

The open structure of the tiles ensures perfect adhesion of the cast floor to the base floor as well as to the wall. This system can also be used as main heating.

If the system is used as a heating/cooling system in the wall, the mat supports the plaster and the MAGNUM Slimfit behaves like a reinforcement.

MAGNUM Slimfit 12 is developed for the 12 mm MAGNUM Tube. The 12 mm tube is supplied in lengths of 100 and 300 metres. The maximum tube length per group is 100 metres.

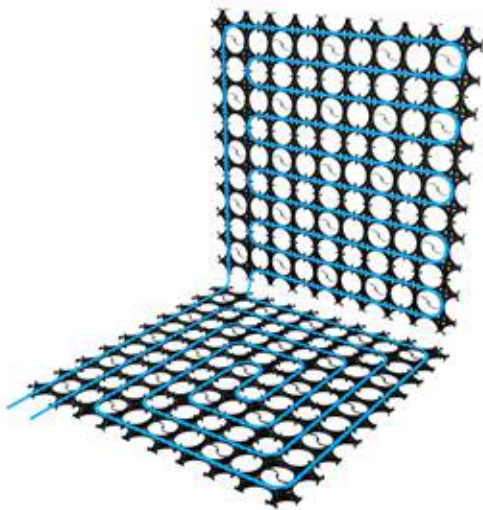

Specifications

System type	Water based
System height	14 mm (incl. tube)
System width	from 20 cm
Min. setting height	17 mm
Installation	Self-levelling / Screed
Power	Variable
In wet areas	✓
Tiles	✓
Wood	✓ (i.c.w. self-levelling)
(PVC) Laminate	✓ (i.c.w. self-levelling)
Carpet	✓ (i.c.w. self-levelling)
Certification	CE, KOMO, MPA, SKZ
Warranty	50 years



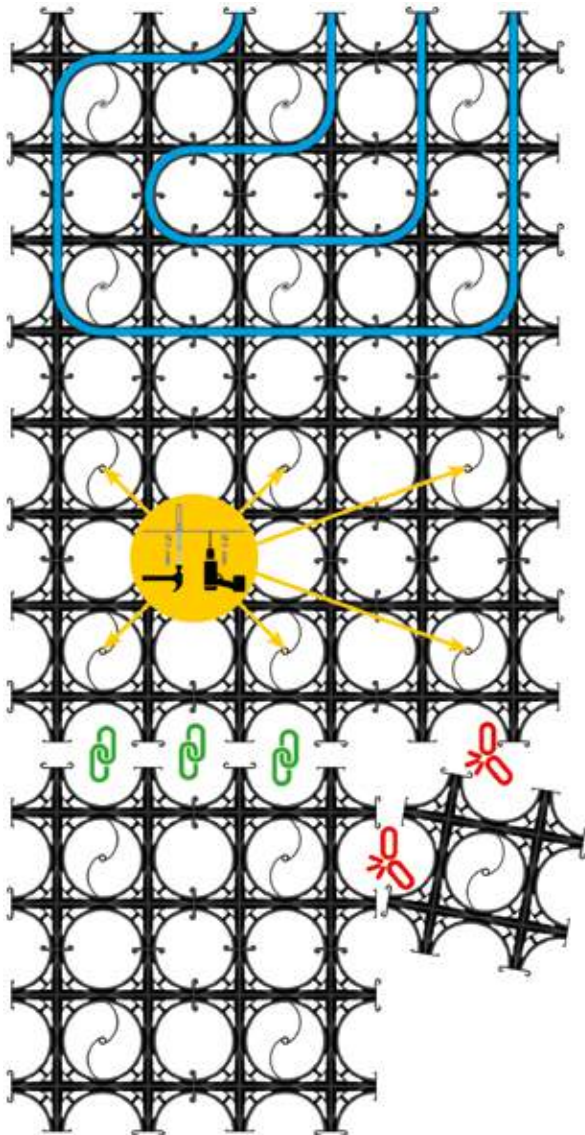

Technical details

- LxW SlimFit elements 1000 x 750 mm (4x3 components)
- Component dimensions 250 x 250 mm
- Surface area per element 0,75 m²
- Surface area per pack 3,75 m² (5 elements)
- System installation height 14 mm
- Total mounting height 17-22 mm
- Centre-to-centre distance tube 125 mm
- Suitable for tube size Ø 12 mm

Installation methods

For mounting (floor or wall)

- Drill size 5 mm
- Hammer plug size 5 mm

Pattern

- Floor Reverse Spiral
- Wall Meander

Finish

- Floor Leveling compound or (sand)cement
- Wall Plaster mortar

Warranty

MAGNUM SlimFit has a 2 year guarantee on the elements, the floor heating pipe has a 50 year guarantee.



Art.nr.	Description	m ²	Dimensions
W61012	MAGNUM SlimFit 12 system	3,75 m ²	5 plates of 75 x 100 cm

Art.nr.	Description	m	Dimensions
W12100	MAGNUM Tube PE-RT	100 m	12 x 1,5 mm
W12300	MAGNUM Tube PE-RT	300 m	12 x 1,5 mm

Art.nr.	Description	Dimensions
W90012	MAGNUM Adaptor / Euroconus connection	12 x 1,5 x 3/4" mm
W91201	PUSH connection set for 1x 80 m tube 12 mm	
W91202	PUSH connection set for 2x 80 m tube 12 mm	
W91203	PUSH connection set for 3x 80 m tube 12 mm	

MAGNUM FiberBoard

System plates

Fibre plasterboards are used as a carrier for pipes in dry floor heating systems. Due to the properties of the fibre plaster, the panels allow heat to spread effectively over the heating space. When using fibre plasterboards, the installation of heat transfer plates is not necessary. The panels are 18 mm thick and are only suitable for a Ø12 mm underfloor heating pipe. The fixed pipe spacing is 12 cm.

FiberBoard Multi

Width 600 mm
 Length 600 mm
 Thickness 8 mm
 H.o.h. 120 mm

FiberBoard Connect

This EPS board can be used to guide the tube from the distributor to the heating surface. A maximum of 10 groups can be placed on the board.

Width 1200 mm
 Length 600 mm
 Thickness 18 mm

FiberBoard Combi

Width 1200 mm
 Length 600 mm
 Thickness 18 mm
 H.o.h. 120 mm

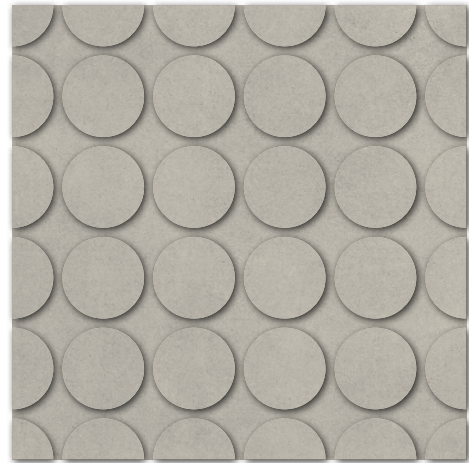

Art. W63001
FiberBoard Multi

Specifications

System type	Water-based
System height	18 mm
System width	from 20 cm
Min. installation height	18 mm
Installation	Floating
Tube spacing	120 mm (fixed)
In wet areas	X
Tiles	V (i.c.w. Knauf or fermacell min. 12 mm)
Wood	V
Laminate	V
Carpet	V (i.c.w. DuoBoard)
Test	CE
Warranty	2 years



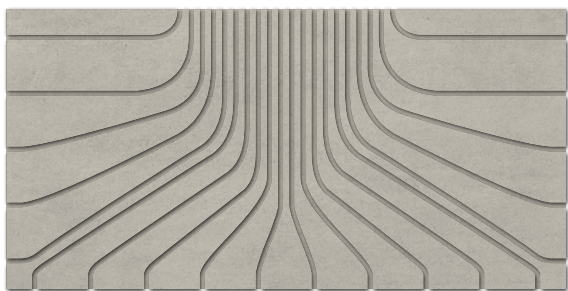

Art. W63002
FiberBoard Connect



Art. W63003
FiberBoard Combi

Technical details

- Gypsum, cellulose fibre
- Density [kg /m³]: 1150
- Declared thermal conductivity λ [W/(m*K)]: 0.32
- Declared thermal resistance R [(m²*K)/W]: 0.056 (18 mm)
- Mechanical sound insulation EN ISO 140-6 Ln,w [dB]: 53
- Airborne sound insulation EN ISO 140-3 Rw [dB]: 54
- Water vapour diffusion resistance value μ : 13
- Swelling after 24 hours contact with water: <2%
- Fire class according to EN 13501-1: A2

Installation methods

For mounting (floor or wall)

Drill hole size 5 mm

Impact plug size 5 mm

Laying pattern

Floor Snail shell

Wall Meander

Finishing

Floor Levelling compounds or (sand) cement

Wall Plaster mortar

Warranty

MAGNUM FiberBoard has a 2-year warranty on the elements, underfloor heating pipe has a 50-year warranty.

Art. no.	Description	Weight
W63001	FiberBoard Multi - 60 x 60 cm - 18 mm for MAGNUM Tube 12 x 1,5 mm	5,9 kg
W63002	FiberBoard Connect- 120 x 60 cm - 18 mm for MAGNUM Tube 12 x 1,5 mm	15 kg
W63003	FiberBoard Combi 120 x 60 cm - 18 mm for MAGNUM Tube 12 x 1,5 mm	15 kg

MAGNUM Tacker system Positioning systems and accessories

Tacker Grid foil

For installations directly on insulation, Tacker Grid foil can be used. This grid foil has a rectangular division of 10 cm x 10 cm and an inner grid of 5 cm x 5 cm. This means that underfloor heating tubes can be laid at different centre-to-centre distances.

Tacker Insulation plates

With this type of underfloor heating installation, the tubes are fixed to 20 or 30 mm thick insulation plates using tacker staples. This system is ideal if you want to install underfloor heating and floor insulation over a large area. To allow the floor to expand and contract, it is important that edge insulation is placed against all walls.



Specifications

System type	Water based
System height	20 or 30 mm
System width	1000 mm
Min. setting height	5 cm above the tube
Installation	Floating / Pasting
In wet areas	✓
Tiles	✓
Wood	✓
(PVC) Laminate	✓
Carpet	✓
Certification	DIN 13163, DIN 4108-10, building material class B2 in accordance with DIN 4102-B2
Warranty	2 years



Tacker staples and device

The Tacker system consists of insulation plates on which floor heating pipes can be directly fastened using 40 or 60 mm plastic staples. These staples are fastened with the Tacker stapler.

Technical details

- Dimensions 10000 x 1000 mm
- Plate thickness 20 or 30 mm
- Thermal resistance 0,444 m²K/w or 0,667 m²K/W
- Max. traffic load 4 kPA (kN/m²)
- Impact noise improvement 28 dB or 29 dB
- Nominal value according to DIN 4108-4 0,045 W/mK
- Dimensions Tacker staples 40 x 18,5 x 6 mm
The staples 38 mm are suitable for the installation of tubes with a diameter of 14-20 mm.
- Dimensions Tacker stapler 800 x 140 x 70 mm

Warranty

MAGNUM Tacker system has a 2 year warranty.



Art.nr.	Description	m ²	Dimensions
W90102	Tacker Grid foil	50 m ²	50 m x 1 m

Art.nr.	Description	m ²	Dimensions
W90103	MAGNUM Tacker Insulation Plate	10 m ²	Thermal 20 mm
W90104	MAGNUM Tacker Insulation Plate	10 m ²	Thermal 30 mm
W90122	MAGNUM Tacker Insulation Plate	10 m ²	Acoustic 20 mm
W90123	MAGNUM Tacker Insulation Plate	10 m ²	Acoustic 30 mm

Art.nr.	Description	Dimensions
W90105	Tacker Staples	40 mm 300 pieces
W90106	Tacker Staples	60 mm 300 pieces

Art.nr.	Description
W90107	Tacker Stapler

MAGNUM Castellated Plates

Positioning systems and accessories

Castellated plates

Castellated plates are specially designed to simplify the preparation of the floor for the installation of heating tubes, which reduces the installation time. The castellated plates also make it possible to fix underfloor heating tubes in a quick and easy way. Available as 17 mm uninsulated and in 28 or 47 mm insulated.

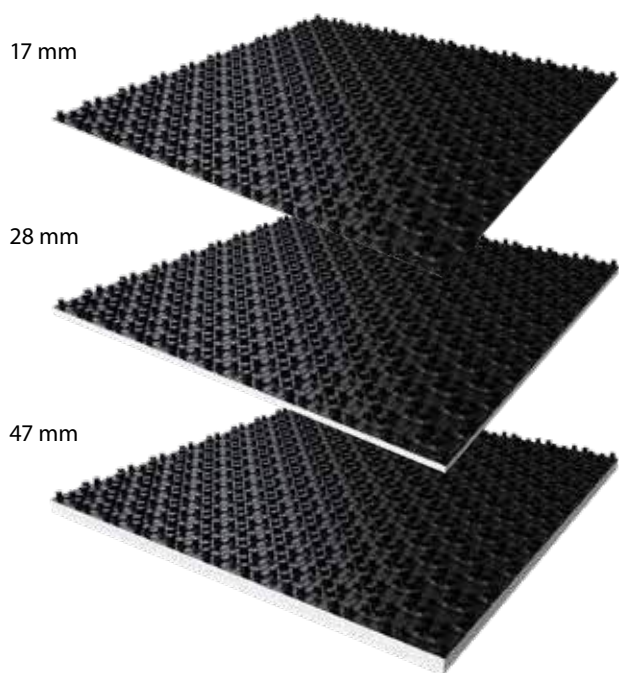

Specifications

System type	Water based
System height	17, 28 or 47 mm
System width	1 x 1 m
Min. setting height	5 cm above the tube
Installation	Floating / Pasting
In wet areas	✓
Tiles	✓
Wood	✓
(PVC) Laminate	✓
Carpet	✓
Certification	DIN 4108-10, building material class B2 according to DIN 4102-B2
Warranty	2 years



Technical details

Knob element with EPS thermal insulation plate according to DIN EN 13163, PS foil with tread seal and EPS tube knob on the back for heating tubes 14-16 mm. Two-sided foil overlay for screed-tight connection. Application for interior insulation on ceilings or floor plates according to DIN 4108-10, building material class B2 according to DIN 4102-B2.

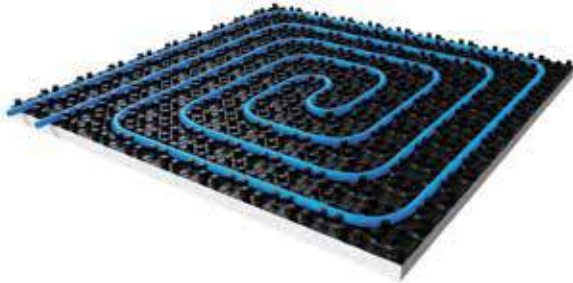

- Fire behaviour according to EN 13501 = Class E
- Building material class in accordance with DIN 4102 = B2
- Application according to EN 13163 for interior insulation on ceilings or floorboards according to DIN 4108-10
- EPS (CFK-, HCFK-, HFK- & HBCD-free)
- Flame retardant polymer-FR

28 mm insulated

- Thermal resistance 0,314 m²K/W
- Max. traffic load 150 kPa

47 mm insulated

- Thermal resistance 0,75 m²K/W
- Max. traffic load 5 kPa (kN/m²)
- Impact sound improvement 28 dB
- Nominal value according to DIN 4108-4 0,040 W/mK

Warranty

2 years

Art.nr.	Description	m ²	
W90116	Castellated plates Uninsulated	10 m ²	10 pieces - 17 mm
W90108	Castellated plates Uninsulated	30 m ²	30 pieces - 17 mm

Art.nr.	Description	m ²	
W90117	Castellated plates 28 mm	10 m ²	11 mm EPS - 10 pieces
W90109	Castellated plates 28 mm	20 m ²	11 mm EPS - 20 pieces
W90110	Castellated plates 47 mm	10 m ²	30 mm EPS - 10 pieces

MAGNUM Heatboard W System plates

The 18 mm thin water based underfloor heating system MAGNUM HeatBoard W is directly applicable under floating wood, parquet or laminate floors. Only suitable for dry rooms and ideal for renovations.

Application

MAGNUM HeatBoard W is suitable for use with hard dry floor systems (laminate, wood and parquet). MAGNUM DuoBoard should first be installed between the heating system and the floor covering in the case of soft floor coverings (carpets, PVC laminate and vinyl).

Ease of installation

The system boards can be put together like puzzle pieces. They are also easy to cut to size with a hobby knife. Then the 12 mm MAGNUM Tube underfloor heating tube can easily be clamped in. The fixed tube distance is 12,5 cm. Approximately 8 m¹ (linear metres) of MAGNUM Tube is needed per 1 m². The floor can then be covered with the supplied felt layer on which the top floor can be applied.

The subfloor to which this system is to be applied must be stable, level and clean.



Specifications

System type	Water based
System height	18 mm
System width	from 20 cm
Min. setting height	18 mm
Installation	Floating
Tube distance	Fixed 125 mm
In wet areas	X
Tiles	V (i.c.w. Knauf or Fermacell min. 12 mm)
Wood	V
(PVC) Laminate	V (PVC i.c.w. DuoBoard)
Carpet	V (i.c.w. DuoBoard)
Certification	CE
Warranty	2 years



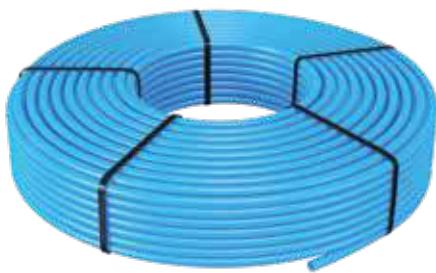

Technical details

- Designation according to standard
EPS-EN13163-T2-L2-S2- P2-DLT(1)5-CS(10)150
- Nominal thickness dL 17 mm
- Coefficient of thermal conductivity 0,036 W/mK DIN V 4108-10
- Thermal resistance 0,33 m²K/W
- Compressive stress 150 kPa (at 10 % compression)
- Load under tension 45 kPa
- Heat resistance < 80°C
- Area of application DEO according to DIN 4108-10
- Fire behaviour Class E according to EN 1350
- Building material class B2 according to DIN 4102
- Material EPS polystyrene hard foam (CFK-free)
- Valid standard EN 13163, DIN V 4108-10

Package content

- 13 plates (4,8 m²)
- Felt layer (5 m²)
- Roll of aluminum tape
- Safety gloves

12 mm MAGNUM Tube, a manifold, necessary connection fittings and possibly DuoBoard must be ordered separately.

Warranty

MAGNUM Heatboard W has a 2 year warranty.

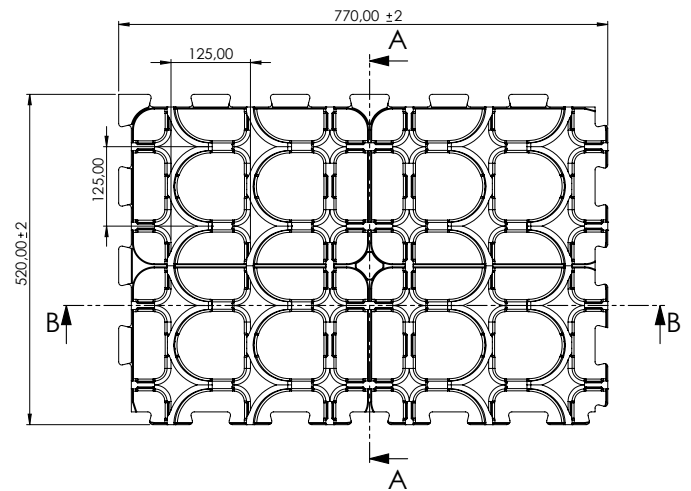

Art.nr.	Description	m ²	Dimensions
W63010	MAGNUM Heatboard 18 mm	4,8 m ²	13 plates of 770 x 520 mm
Art.nr.	Options	m	Dimensions
W12100	MAGNUM Tube PE-RT	100 m	12 x 1,5 mm
W12300	MAGNUM Tube PE-RT	300 m	12 x 1,5 mm
W90012	MAGNUM Adaptor / Euroconus connection		12 x 1,5 x 3/4" mm
W91201	PUSH connection set for 1 x 100 m tube 12 mm		
W91202	PUSH connection set for 2 x 100 m tube 12 mm		
W91203	PUSH connection set for 3 x 100 m tube 12 mm		
430030	DuoBoard 2 x 4 MDF plates	2,88 m ²	1200 x 600 x 3 mm BaseBoard / 4 mm TopBoard

MAGNUM DryFloor (25mm) Underfloor heating system

If you want to install underfloor heating in a room with a low construction height or in places where the supporting construction is less strong (such as wooden subfloors), a dry construction installation offers a solution. The system consists of profiled EPS insulation plates on which steel heat distribution profiles are placed.

Omega profile

The aluminium Omega profiles spread the heat of the underfloor heating system over the floor surface and are placed on top of the 25 mm drywall insulation plates. Due to the high thermal conductivity of the plates, the reaction time compared to traditional systems is much lower (thermal conductivity: 80 W/mK).

As a rule of thumb for ordering, you should consider approximately 8 profiles per m².

The subfloor on which this system is installed must be stable, level and clean.

Attention: When you use these profiles in combination with the dry construction insulation plates, you should use a floor heating tube with a diameter of 14 mm.



Specifications

System type	Water based
System height	25 mm
System width	from 20 cm
Min. setting height	25 mm
Installation	Floating
Power	Variable
In wet areas	X
Tiles	V (i.c.w. Fermacell min. 12 mm)
Wood	V
(PVC) Laminate	V (i.c.w. Fermacell min. 12 mm)
Carpet	V (i.c.w. Fermacell min. 12 mm)
Certification	CE
Warranty	2 years



Technical details

EPS-insulation plates

- Dimensions: 0,75 m² per insulation plate (100 cm x 75 cm)
- Number of pieces per box: 10 plates (7,5 m²)
- Tube spacing: 125 mm (main heating)
- Maximum tube length: 100 m
- Application: insulation plate without impact sound
- Designation according to standard:
EPS-EN13163-T4-L1-W1-S1-P4-DLT(1)5-CS(10)200
- Nominal thickness dL: 25 mm
- Coefficient of thermal conductivity DIN V 4108-10 in W/mK: 0,035
- Thermal resistance in m²K/W: 0,71
- Compressive stress (at 10 % compression): 150 kPa
- Tension load: 60 kPa
- Heat deflection temperature up to 80°C
- Application area according to DIN 4108-10: DEO
- Quality tested: CE / FIW
- Fire behaviour according to EN 13501: Class E
- Building material class in accordance with DIN 4102: B1
- Material EPS polystyrene hard foam (CFK-free)
- Valid standard EN 13163, DIN V 4108-10
- Usable area (L x W) per panel 1,000 x 750 mm
- Usable area per panel 0,75 m²

Aluminium Omega profiles

- Dimensions per profile: 1000 mm x 120 mm
- Thermal conductivity: 80 W/mK
- Number required approx. 8 profiles per m²

Warranty

MAGNUM insulation boards and profiles: 2 years
MAGNUM Tube: 50 years, the first 10 with consequential damages.

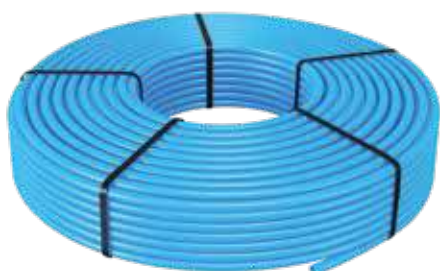

Art.nr.	Description	m ²	Dimensions
W62075	MAGNUM DryFloor 25 mm	7,5 m ²	100 x 75 cm
W62901	Aluminium Omega Profile 14 mm		1000 x 120 x 0,4 mm

Art.nr.	Description	m	Dimensions
W14100	MAGNUM Tube PE-RT	100 m	14 x 2 mm
W14120	MAGNUM Tube PE-RT	120 m	14 x 2 mm
W14240	MAGNUM Tube PE-RT	240 m	14 x 2 mm
W14600	MAGNUM Tube PE-RT	600 m	14 x 2 mm

Art.nr.	Description	Dimensions
W90014	MAGNUM Adaptor / Euroconus connection (per 2)	14 x 2 x 3/4" mm

MAGNUM Tube

Underfloor heating tube

The MAGNUM Tube, floor heating tube, is made of a PE-RT type I and stands for Polyethylene Raised Temperature. This makes the tube also suitable for high temperatures.

PE-RT type I is strong and yet flexible. It is copolymer of ethylene with a unique molecular structure, based on controlled side chain distribution. As a result, it exhibits superior behaviour in terms of stress cracking and resistance to hydrostatic pressure, without the need for cross-linking. This makes MAGNUM Tube recyclable.

This PE-RT Type I is optimally stabilised against ageing, so that the MAGNUM Tube has a calculated life span of at least 50 years under normal conditions of use. The PE-RT type I MAGNUM Tube has been specially developed for use in hot and cold water systems, floor and wall heating/cooling and ceiling cooling.

The PE-RT type I feedstock, has been a leader for more than 20 years in tube applications where a wide temperature range is required.

The MAGNUM Tube can be used in a temperature range from 5°C to 80°C. Short-term peak loads of up to 95°C at a maximum internal hydrostatic overpressure of 6 bar can be withstood without any problems.



Specifications

Material	PE-RT Type I
Oxygen density	EVOH Low (DIN 4726)
Density	0,933 g/cm ³ (ASTM D-792)
Linear expansion coefficient	20°C - 70°C 0,19 mm/mK (DIN 53752 A)
Coefficient of thermal conductivity	at 60°C 0,4 W/mK (DIN 52612-1)
Deflection point (Vicat)	122°C (ASTM D-1525)
Maximum elongation to failure	> 800% (ISO 527-2)
Bending radius	5 x Diameter
Certification	KOMO, MPA and SKZ
Warranty	50 years of which the first 10 years with consequential damage



Cross section of the PE-RT 5 layered heating tube:

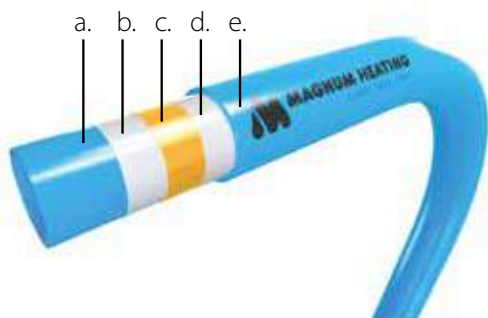

- a. PE-RT, Type 1
- b. Adhesive layer
- c. EVOH layer
- d. Adhesive layer
- e. PE-RT, Type 1

Technical details

- Density 0,933 g/cm³ (ASTM D-792)
- Linear expansion coefficient 20°C - 70°C
0,19 mm/mK (DIN 53752 A)
- Coefficient of thermal conductivity at 60°C
0,4 Watt/mK (DIN 52612-1)
- Deflection point (Vicat) 122°C (ASTM D-1525)
- Maximum elongation to failure > 800% (ISO 527-2)
- Bending radius 5 x Diameter
- Oxygen density EVOH Low (DIN 4726)
- With KOMO, MPA and SKZ certification

Warranty

50 years of which the first 10 years with consequential damage.

Art.nr.	Description	Length	Dimensions
	10 mm for MAGNUM SlimFit 10 system		
W10080	MAGNUM Tube, underfloor heating tube PE-RT	80 m	10 x 1,3 mm
W10240	MAGNUM Tube, underfloor heating tube PE-RT	240 m	10 x 1,3 mm
Art.nr.	Description	Length	Dimensions
	12 mm for MAGNUM Heatboard W system & MAGNUM SlimFit 12 system		
W12100	MAGNUM Tube, underfloor heating tube PE-RT	100 m	12 x 1,5 mm
W12300	MAGNUM Tube, underfloor heating tube PE-RT	300 m	12 x 1,5 mm
Art.nr.	Description	Length	Dimensions
	14 mm		
W14100	MAGNUM Tube, underfloor heating tube PE-RT	100 m	14 x 2 mm
W14120	MAGNUM Tube, underfloor heating tube PE-RT	120 m	14 x 2 mm
W14240	MAGNUM Tube, underfloor heating tube PE-RT	240 m	14 x 2 mm
W14600	MAGNUM Tube, underfloor heating tube PE-RT	600 m	14 x 2 mm
Art.nr.	Description	Length	Dimensions
	16 mm		
W16090	MAGNUM Tube, underfloor heating tube PE-RT	90 m	16 x 2 mm
W16100	MAGNUM Tube, underfloor heating tube PE-RT	100 m	16 x 2 mm
W16120	MAGNUM Tube, underfloor heating tube PE-RT	120 m	16 x 2 mm
W16240	MAGNUM Tube, underfloor heating tube PE-RT	240 m	16 x 2 mm
W16600	MAGNUM Tube, underfloor heating tube PE-RT	600 m	16 x 2 mm
Art.nr.	Description	Length	Dimensions
	18 mm		
W18130	MAGNUM Tube, underfloor heating tube PE-RT	130 m	18 x 2 mm
W18260	MAGNUM Tube, underfloor heating tube PE-RT	260 m	18 x 2 mm
W18520	MAGNUM Tube, underfloor heating tube PE-RT	520 m	18 x 2 mm
Art.nr.	Description	Length	Dimensions
	20 mm		
W20120	MAGNUM Tube, underfloor heating tube PE-RT	120 m	20 x 2 mm
W20240	MAGNUM Tube, underfloor heating tube PE-RT	240 m	20 x 2 mm
W20500	MAGNUM Tube, underfloor heating tube PE-RT	500 m	20 x 2 mm

MAGNUM Basic Steel Floor heating manifold

The MAGNUM Basic Steel is a simple, yet very robust control unit that comes standard with an energy-efficient pump with energy label A. This pump has a constant pressure, so that it adjusts itself when groups are closed off by a possible after-control (actuator). This is also called a modulating pump.

The manifold is hydraulically neutral, which means that the pump of this manifold has no influence on the primary circuit. The manifold is pressure tested at 6 bar provided with a press report, clear instruction manual and warranty card.

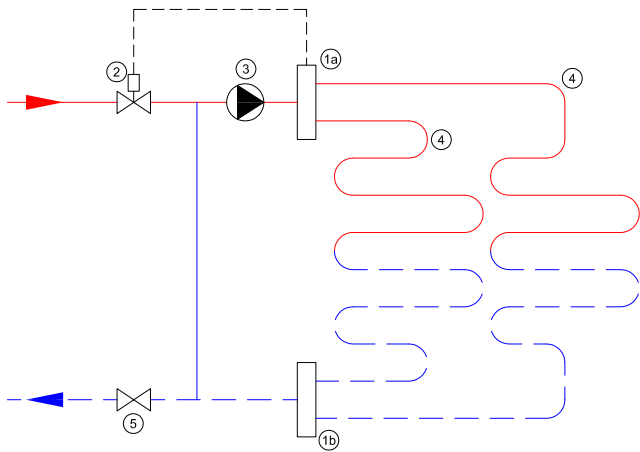

1a	Manifold
1b	Collector
2	Thermostatic valve
3	Circulation pump
4	Underfloor heating group(s)
5	Valve

Application

Central heating boiler	V
Heat pump	X
Solar heat (with buffer tank)	X
Pellet stove	X
District heating	X

Specifications

Valve on inlet	V
Thermostat on inlet	V
Pump	V
Flow meter	X
Thermometer	V
Pressure gauge	X
Air vent	V
Valve on return	V
RTL valve on return	X
In control valve mixing quantity	X
Stop valve between supply and return	X
Keuring	CE



Technical details

- The body of this manifold is galvanised and epoxy-coated in black RAL 9011
- Equipped with thermostat knob, thermometer, maximum safety device and air vent
- Equipped as standard with an A-rated pump
- Double adjustable thermostatic group valves suitable for MAGNUM actuators
- Group connections suitable for ¾" Euroconus
- Primary connection ½" (from 8 groups ¾")
- Distributor is supplied with mounting material as standard
- Thermostatically prepared valve
- Thermostat knob with cap valve in immersion tube
- Bimetal thermometer incl. immersion tube
- Air vent 1/2"
- Ball valve 1/2" 2-piece blue

Package content

- Press report
- Installation instructions
- Warranty certificate
- Basic Steel

Warranty

MAGNUM Basic Steel 5 years for the body, 2 years for fittings.

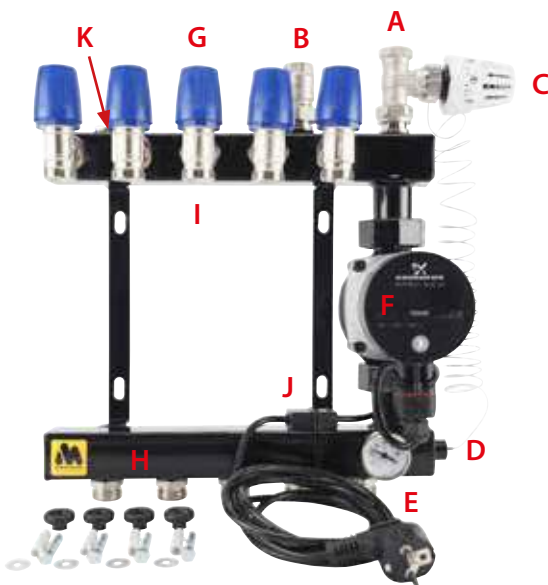

- A. Supply pipe (central heating)
- B. Return pipe (central heating)
- C. Thermostat knob
- D. Temp. sensor (in tube)
- E. Temperature gauge
- F. A-Label Pump
- G. Group valves
- H. Supply MAGNUM Tube
- I. Return MAGNUM Tube
- J. Maximum protection
- K. Air vent

Art.nr.	Description	Dimensions
W40001	MAGNUM Basic Steel incl. A-Label Pump	190 x 390 x 145 mm
W40002	MAGNUM Basic Steel 2 Groups incl. A-Label Pump	190 x 390 x 145 mm
W40003	MAGNUM Basic Steel 3 Groups incl. A-Label Pump	245 x 390 x 145 mm
W40004	MAGNUM Basic Steel 4 Groups incl. A-Label Pump	300 x 390 x 145 mm
W40005	MAGNUM Basic Steel 5 Groups incl. A-Label Pump	355 x 390 x 145 mm
W40006	MAGNUM Basic Steel 6 Groups incl. A-Label Pump	410 x 390 x 145 mm
W40007	MAGNUM Basic Steel 7 Groups incl. A-Label Pump	465 x 390 x 145 mm
W40008	MAGNUM Basic Steel 8 Groups incl. A-Label Pump	520 x 390 x 145 mm
W40009	MAGNUM Basic Steel 9 Groups incl. A-Label Pump	575 x 390 x 145 mm
W40010	MAGNUM Basic Steel 10 Groups incl. A-Label Pump	630 x 390 x 145 mm

MAGNUM Front Steel Floor heating manifold

This MAGNUM control unit is very compact and made of galvanised and epoxy coated steel. This allows MAGNUM to give a 5-year guarantee on the housing of this manifold. The manifold is equipped with a A-label pump as standard. Standard with a primary top connection. This pump has a constant pressure, so it adapts itself when groups are closed off by a possible after-control (actuator).

The manifold is basically hydraulically neutral. If the mixing valve is closed in the hydraulically active

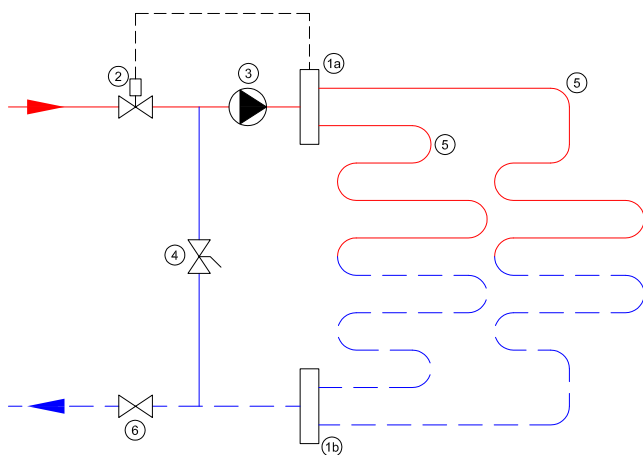

1a	Manifold
1b	Collector
2	Thermostatic valve
3	Circulation pump
4	Regulating valve
5	Underfloor heating group(s)
6	Valve

Application

Central heating boiler	V
Heat pump	X
Solar heat (with buffer tank)	V
Pellet stove	V
District heating	V (on request)

Specifications

Valve on inlet	V
Thermostat on inlet	V
Pump	V
Flow meter	X
Thermometer	V
Pressure gauge	X
Air vent	V
Valve on return	V
RTL valve on return	X
In control valve mixing quantity	V
Stop valve between supply and return	X
Inspection	CE



Technical details

- The body of this manifold is galvanised and epoxied steel
- Equipped with thermometer, air vent and maximum safety device
- Equipped as standard with an energy-efficient A-Label pump
- Thermostatic group valves M30x 1,5 suitable for MAGNUM actuators
- Group connections suitable for 3/4" Eurocones
- Primary connection 1/2" (from 8 groups 3/4")
- Manifold is supplied with mounting material as standard
- Thermostatically prepared valve
- Thermostat knob with cap valve in immersion tube
- Bimetal thermometer incl. immersion tube
- Air vent 1/2"
- Ball valve 1/2" 2-part blue
- Valve insert LTV manifold

Package content

- Press report
- Installation instructions
- Warranty certificate
- MAGNUM Front Steel

Warranty

MAGNUM Basic Steel 5 years for the body, 2 years for fittings.

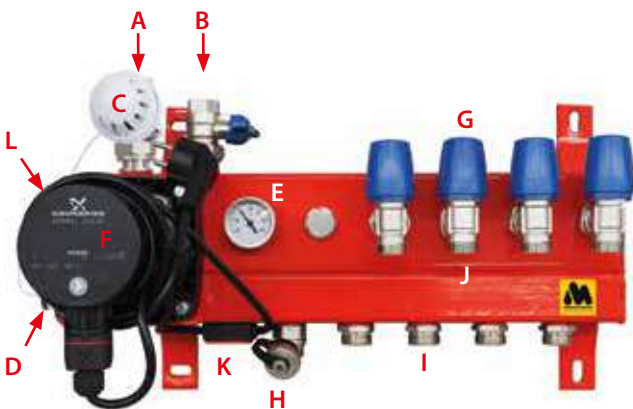

- A. Supply pipe (central heating)
- B. Return pipe (central heating)
- C. Thermostat knob
- D. Temperature sensor
- E. Temperature gauge
- F. A-Label Pump
- G. Group valves
- H. Filling Nipple
- I. Supply MAGNUM Tube
- J. Return MAGNUM Tube
- K. Maximum protection
- L. Mixing valve

Art.nr.	Description	Dimensions
W41001	MAGNUM Front Steel incl. A-Label pump	325 x 235 x 185 mm
W41002	MAGNUM Front Steel 2 Groups incl. A-Label pump	325 x 235 x 185 mm
W41003	MAGNUM Front Steel 3 Groups incl. A-Label pump	375 x 235 x 185 mm
W41004	MAGNUM Front Steel 4 Groups incl. A-Label pump	425 x 235 x 185 mm
W41005	MAGNUM Front Steel 5 Groups incl. A-Label pump	475 x 235 x 185 mm
W41006	MAGNUM Front Steel 6 Groups incl. A-Label pump	525 x 235 x 185 mm
W41007	MAGNUM Front Steel 7 Groups incl. A-Label pump	575 x 235 x 185 mm
W41008	MAGNUM Front Steel 8 Groups incl. A-Label pump	625 x 235 x 185 mm
W41009	MAGNUM Front Steel 9 Groups incl. A-Label pump	675 x 235 x 185 mm
W41010	MAGNUM Front Steel 10 Groups incl. A-Label pump	725 x 235 x 185 mm
W41011	MAGNUM Front Steel 11 Groups incl. A-Label pump	775 x 235 x 185 mm
W41012	MAGNUM Front Steel 12 Groups incl. A-Label pump	825 x 235 x 185 mm
W41013	MAGNUM Front Steel 13 Groups incl. A-Label pump	875 x 235 x 185 mm
W41014	MAGNUM Front Steel 14 Groups incl. A-Label pump	925 x 235 x 185 mm
W41015	MAGNUM Front Steel 15 Groups incl. A-Label pump	975 x 235 x 185 mm

MAGNUM Premium Plastic Floor heating manifold

This professional MAGNUM Premium Plastic control unit is very compact and consists of individual plastic elements connected by threaded rods.

The individual elements are made of a glass-fibre-reinforced polyamide plastic that is very suitable for high but also low temperatures. The elements have a double-walled construction that automatically forms an insulating layer, making this manifold ideal for heating as well as cooling. This insulation layer virtually eliminates the formation of condensation on the manifold.

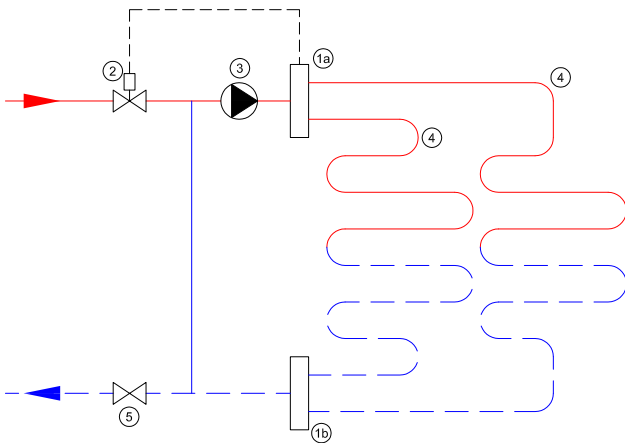

1a	Manifold
1b	Collector
2	Thermostatic valve
3	Circulation pump
4	Underfloor heating group(s)
5	Valve

Application

Central heating boiler	V
Heat pump	X
Solar heat (with buffer tank)	V
Pellet stove	V
District heating	V (on request)

Specifications

Valve on inlet	V
Thermostat on inlet	V
Pump	V
Flow meter	V
Thermometer	V
Pressure gauge	V
Air vent	V
Valve on return	V
RTL valve on return	X
In control valve mixing quantity	X
Stop valve between supply and return	X
Inspection	CE



Technical details

- Equipped as standard with an energy-efficient Grundfos A-Label pump
- Thermostatic group valves M30x 1,5 suitable for MAGNUM actuators
- Group connections suitable for 3/4" Eurocones
- Groups fitted with professional flow meters with a range of 0-2,5L/min
- Primary connection 1/2" (from 8 groups 3/4")
- Equipped with thermometer, air vent, maximum safety valve and filler tap
- Thermostatically prepared valve 1/2" (from 8 groups 3/4")
- Thermostat knob with cap valve in immersion tube
- Grundfos A-label pump
- Flow meter Camflux 2,5 L/m- 1/2"
- Manothermometer 60mm Axial incl. immersion tube
- Air vent 1/2"
- Ball valve 1/2" 2-part blue (from 8 groups 3/4")

Installation method

The water temperature can be set with a thermostat head. The manifold is also equipped with a maximum safety device to prevent too hot water being pumped into the floor.

Package content

- Press report
- Installation instructions
- Warranty certificate
- MAGNUM Premium Plastic Manifold

Warranty

MAGNUM Premium Plastic 10 years on body, 2 years on valves.

- A. Supply pipe (central heating)
- B. Return pipe (central heating)
- C. Flow meter
- D. Group valves
- E. Filling nipple
- F. Supply MAGNUM Tube
- G. Return MAGNUM Tube
- H. Pressure gauge
- I. Thermostat knob
- J. Temperature gauge
- K. Maximum protection
- L. A-label pump

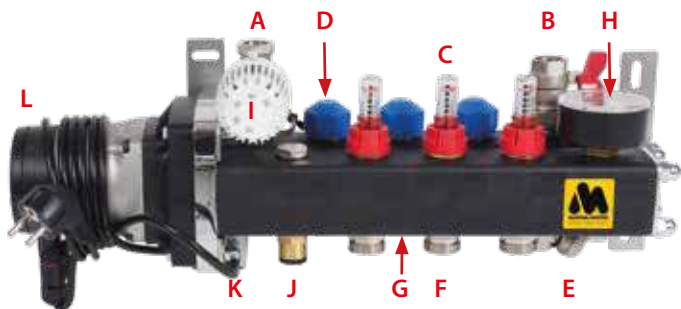

Art.nr.	Description	Dimensions
W51001	MAGNUM Premium Plastic Manifold	390 x 200 x 170 mm
W51002	MAGNUM Premium Plastic Manifold 2 Groups	445 x 200 x 170 mm
W51003	MAGNUM Premium Plastic Manifold 3 Groups	500 x 200 x 170 mm
W51004	MAGNUM Premium Plastic Manifold 4 Groups	555 x 200 x 170 mm
W51005	MAGNUM Premium Plastic Manifold 5 Groups	610 x 200 x 170 mm
W51006	MAGNUM Premium Plastic Manifold 6 Groups	665 x 200 x 170 mm
W51007	MAGNUM Premium Plastic Manifold 7 Groups	720 x 200 x 170 mm
W51008	MAGNUM Premium Plastic Manifold 8 Groups	775 x 200 x 170 mm
W51009	MAGNUM Premium Plastic Manifold 9 Groups	830 x 200 x 170 mm
W51010	MAGNUM Premium Plastic Manifold 10 Groups	885 x 200 x 170 mm
W51011	MAGNUM Premium Plastic Manifold 11 Groups	940 x 200 x 170 mm
W51012	MAGNUM Premium Plastic Manifold 12 Groups	995 x 200 x 170 mm
W51013	MAGNUM Premium Plastic Manifold 13 Groups	1050 x 200 x 170 mm
W51014	MAGNUM Premium Plastic Manifold 14 Groups	1105 x 200 x 170 mm
W51015	MAGNUM Premium Plastic Manifold 15 Groups	1160 x 200 x 170 mm

MAGNUM Premium Stainless Steel Open LT Floor heating manifold

The MAGNUM Premium Stainless Steel Open manifold is used in low temperature installations and is made of the very high quality 4301 stainless steel. This manifold is fitted as standard with 1" ball valves, 1 automatic air vent, 2 drain valves and a pressure gauge.

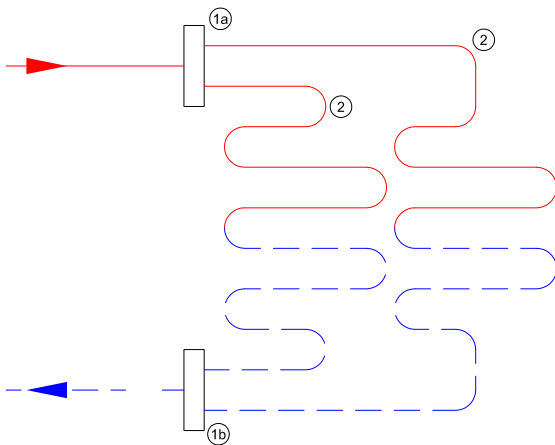
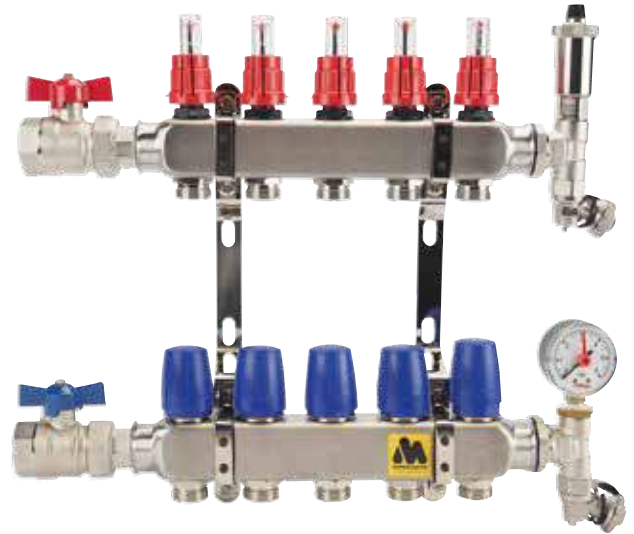

1a	Manifold
1b	Collector
2	Underfloor heating group(s)

Application

Central heating boiler	V
Heat pump	V
Solar heat (with buffer tank)	V
Pellet stove	V
District heating	V

Specifications

Valve on inlet	V
Thermostat on inlet	X
Pump	X
Flow meter	V
Thermometer	X
Pressure gauge	V
Air vent	V
Valve on return	V
RTL valve on return	X
In control valve mixing quantity	X
Stop valve between supply and return	X
Inspection	CE



Technical details

- The body of this manifold is stainless steel 4301
- Thermostatic group valves M30x 1,5 suitable for MAGNUM actuators
- Groups fitted with professional flow meters with a range of 0-2,5L/min
- Group connections suitable for ¾" Eurocones
- Primary connection 1" Sealable by ball valves
- Manifold is supplied with mounting material as standard
- Ball valve 1" with red handle
- Flow meter Camflux 2,5 L/m- 1/2"
- Pressure gauge 40 mm axial 1/8"
- Automatic air vent nickel-plated 1/2" + O-ring
- Ball valve 1" with blue handle

Package content

- Press report
- Installation instructions
- Warranty certificate
- MAGNUM Premium stainless steel Open LT

Warranty

MAGNUM Premium stainless steel Open LT 10 years on body, 2 years on fittings.

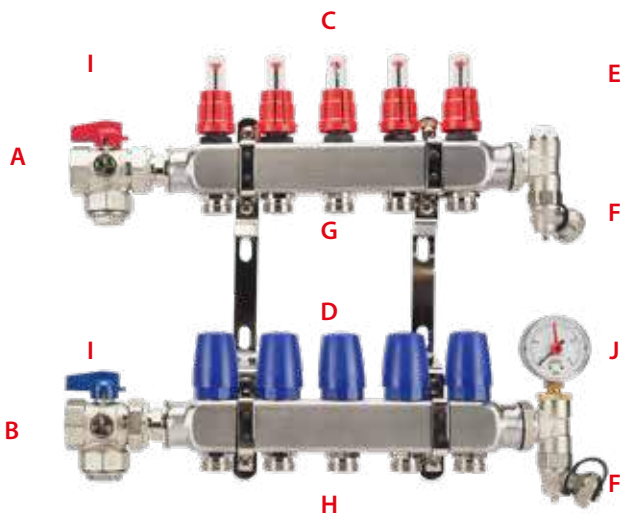

- A. Supply pipe (central heating)
- B. Return pipe (central heating)
- C. Flow meter
- D. Group valves
- E. Automatic air vent
- F. Filling nipple
- G. Supply MAGNUM Tube
- H. Return MAGNUM Tube
- I. Ball valve
- J. Pressure gauge

Art.nr.	Description	Dimensions
W32002	MAGNUM Premium Stainless Steel Open LT 2 Groups	270 x 380 x 100 mm
W32003	MAGNUM Premium Stainless Steel Open LT 3 Groups	320 x 380 x 100 mm
W32004	MAGNUM Premium Stainless Steel Open LT 4 Groups	370 x 380 x 100 mm
W32005	MAGNUM Premium Stainless Steel Open LT 5 Groups	420 x 380 x 100 mm
W32006	MAGNUM Premium Stainless Steel Open LT 6 Groups	470 x 380 x 100 mm
W32007	MAGNUM Premium Stainless Steel Open LT 7 Groups	520 x 380 x 100 mm
W32008	MAGNUM Premium Stainless Steel Open LT 8 Groups	570 x 380 x 100 mm
W32009	MAGNUM Premium Stainless Steel Open LT 9 Groups	620 x 380 x 100 mm
W32010	MAGNUM Premium Stainless Steel Open LT 10 Groups	670 x 380 x 100 mm
W32011	MAGNUM Premium Stainless Steel Open LT 11 Groups	720 x 380 x 100 mm
W32012	MAGNUM Premium Stainless Steel Open LT 12 Groups	770 x 380 x 100 mm
W32013	MAGNUM Premium Stainless Steel Open LT 13 Groups	820 x 380 x 100 mm
W32014	MAGNUM Premium Stainless Steel Open LT 14 Groups	870 x 380 x 100 mm
W32015	MAGNUM Premium Stainless Steel Open LT 15 Groups	955 x 365 x 100 mm

MAGNUM Premium Plastic Open LT Floor heating manifold

The MAGNUM Premium Plastic Open manifold consists of individual plastic elements that are connected by threaded rods.

The individual elements are made of a glass-fibre reinforced polyamide plastic that is very suitable for high and low temperatures. The elements have a double-walled construction that automatically forms an insulating layer. This makes this manifold extremely suitable for heating, but also for cooling. This insulating layer practically eliminates the formation of condensation on the manifold. This manifold is increasingly used in combination with a heat pump, which heats in the winter and cools in the summer. This manifold is equipped as standard with 1" ball valves, 2 automatic air vents, 2 filler drain valves, thermometer and a thermo-manometer.

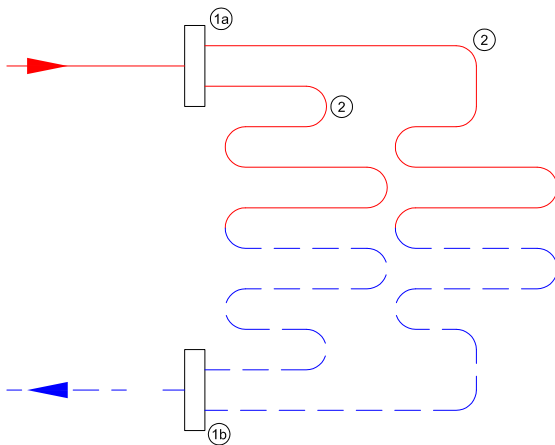

1a	Manifold
1b	Collector
2	Underfloor heating group(s)

Application

Central heating boiler	V
Heat pump	V
Solar heat (with buffer tank)	V
Pellet stove	V
District heating	V

Specifications

Valve on inlet	V
Thermostat on inlet	X
Pump	X
Flow meter	V
Thermometer	V
Pressure gauge	V
Air vent	V
Valve on return	V
RTL valve on return	X
In control valve mixing quantity	X
Stop valve between supply and return	X
Inspection	CE



Technical details

- Constructed from separate plastic elements, with a 10 year guarantee
- Thermostatic group valves M30x 1,5 suitable for MAGNUM actuators
- Groups fitted with a professional flow meter with a range of 0-2,5L/min
- Group connections suitable for ¾" Eurocones
- Primary connection 1" Sealable by ball valves
- Manifold is supplied with mounting material as standard
- Ball valve 1" with red handle
- Flowmeter Camflux 2,5 L/m- 1/2"
- Bi-metal thermometer incl. DB
- Automatic air vent nickel-plated 1/2" + O-ring
- Ball valve 1" with blue handle

Package content

- Press report
- Installation instructions
- Warranty certificate
- MAGNUM Premium Plastic Open LT

Warranty

MAGNUM Premium Plastic Open LT 10 years on body, 2 years on fittings.

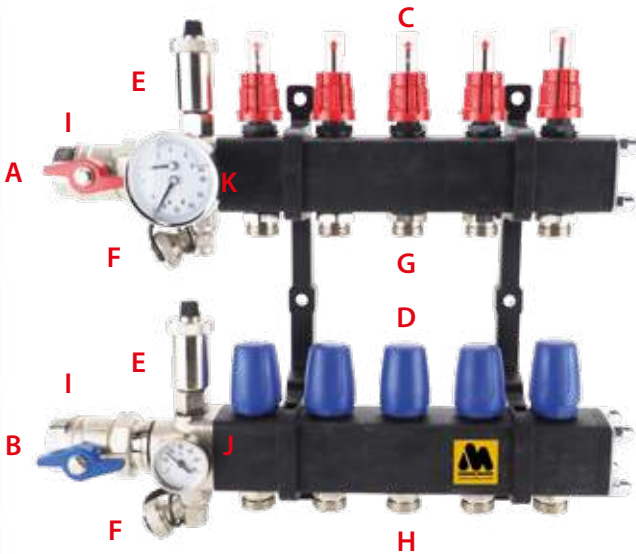

- A. Supply pipe (central heating)
- B. Return pipe (central heating)
- C. Flow meter
- D. Group valves
- E. Automatic air vent
- F. Filling Nipple
- G. Supply MAGNUM Tube
- H. Return MAGNUM Tube
- I. Ball valve
- J. Temperature indicator
- K. Thermo/Manometer

Art.nr.	Description	Dimensions
W50002	MAGNUM Premium Plastic Open LT 2 Groups	265 x 375 x 125 mm
W50003	MAGNUM Premium Plastic Open LT 3 Groups	320 x 375 x 125 mm
W50004	MAGNUM Premium Plastic Open LT 4 Groups	375 x 375 x 125 mm
W50005	MAGNUM Premium Plastic Open LT 5 Groups	430 x 375 x 125 mm
W50006	MAGNUM Premium Plastic Open LT 6 Groups	485 x 375 x 125 mm
W50007	MAGNUM Premium Plastic Open LT 7 Groups	540 x 375 x 125 mm
W50008	MAGNUM Premium Plastic Open LT 8 Groups	595 x 375 x 125 mm
W50009	MAGNUM Premium Plastic Open LT 9 Groups	650 x 375 x 125 mm
W50010	MAGNUM Premium Plastic Open LT 10 Groups	705 x 375 x 125 mm
W50011	MAGNUM Premium Plastic Open LT 11 Groups	760 x 375 x 125 mm
W50012	MAGNUM Premium Plastic Open LT 12 Groups	815 x 375 x 125 mm
W50013	MAGNUM Premium Plastic Open LT 13 Groups	870 x 375 x 125 mm
W50014	MAGNUM Premium Plastic Open LT 14 Groups	925 x 375 x 125 mm
W50015	MAGNUM Premium Plastic Open LT 15 Groups	980 x 375 x 125 mm

Pump/temperature regulator For open floor heating manifolds

The temperature regulator makes MAGNUM Premium Stainless Steel Open LT or MAGNUM Premium Plastic Open LT suitable for high temperature systems. The controller mixes the warm supply water from the boiler back in order to obtain the correct temperature for the underfloor heating system.

The controller is equipped with an energy-efficient A-Label pump as standard.

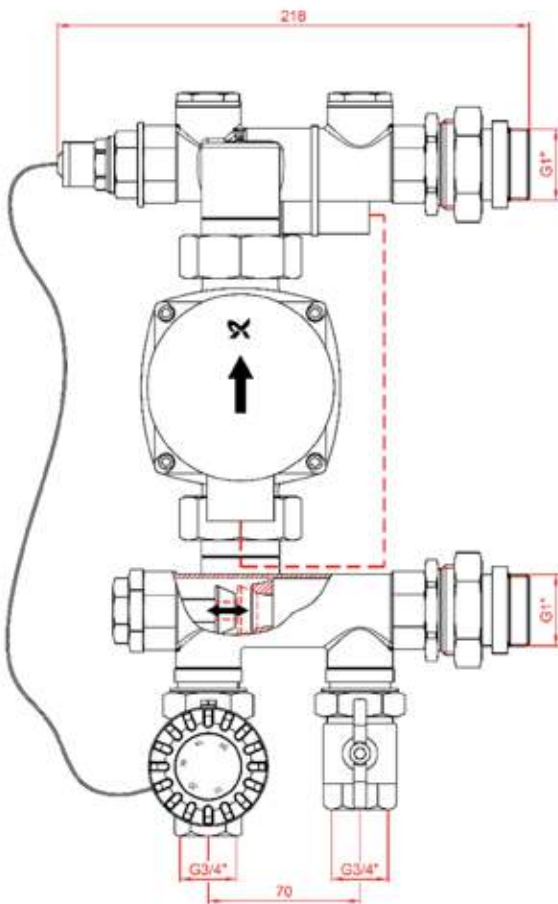

Suitable for

Basic Steel	X
Front Steel	X
Premium Plastic Pro	X
Premium Stainless Steel Open LT	V
Premium Plastic Open LT	V

Specifications

Valve on inlet	V
Thermostat on inlet	V
Pump	V
Flow meter	X
Thermometer	X
Pressure gauge	X
Air vent	V
Valve on return	V
RTL valve on return	X
In control valve mixing quantity	V
Stop valve between supply and return	X



Technical details

- Thermostatically prepared valve 3/4"
- Thermostat knob with cap valve in immersion tube
- A-Label pump
- Ball valve 3/4" 2-part blue
- Valve insert LTV manifold

Warranty

The A-Label pump/temperature regulator has a 10 year guarantee on the body, 2 years on the fittings.

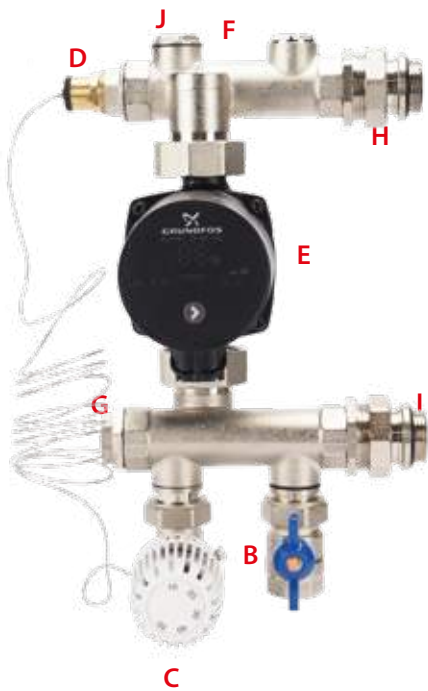
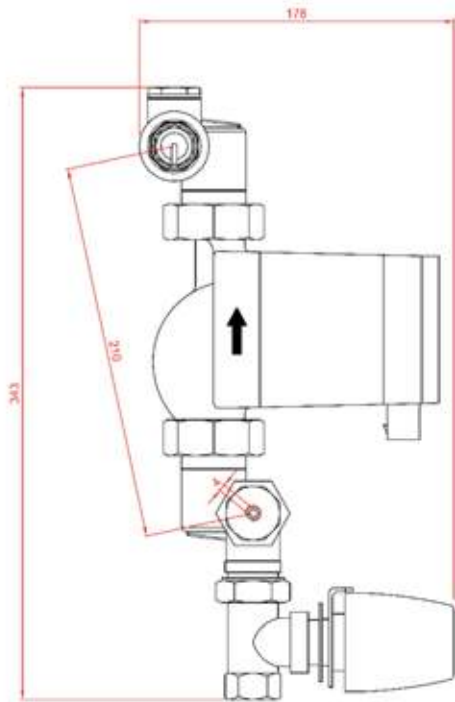

- A. Supply primary
- B. Primary return
- C. Thermostat knob
- D. Temperature sensor
- E. A-Label Pump
- F. Maximum protection
- G. LTV mixing valve
- H. Underfloor heating supply
- I. Underfloor heating return
- J. Air vent

Art.nr.	Description
W90002	A-Label Pump/temperature regulator

MAGNUM Euroconus Connection fittings

Euroconus connection fittings are the ideal fittings for attaching the tubes of your underfloor heating system to the manifold. MAGNUM supplies connection fittings suitable for all MAGNUM Tube underfloor heating tubes with a diameter of 10 mm, 12 mm, 14 mm, 15 mm, 16 mm, 18 mm or 20 mm and a wall thickness up to 2,0 mm (supplied per 2 pieces).

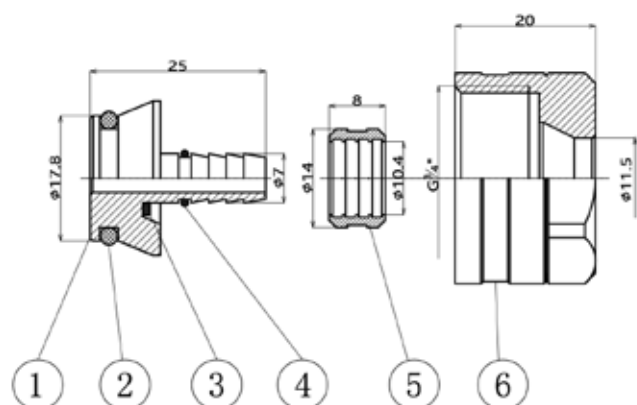

6	Locking cap
5	Open ferrule
4	O-ring
3	Flat gasket
2	O-ring
1	Connector

Specifications

Diameter	10 mm
Dimensions	1,3 x 3/4" mm
Diameter	12 mm
Dimensions	1,5 x 3/4" mm
Diameter	14 mm
Dimensions	2 x 3/4" mm
Diameter	16 mm
Dimensions	2 x 3/4" mm
Diameter	18 mm
Dimensions	2 x 3/4" mm
Diameter	20 mm
Dimensions	2 x 3/4" mm
Warranty	2 years



Art.nr.	Description	Dimensions
W90010	MAGNUM Adaptor / Euroconus connection 10 mm	1,3 x 3/4" mm
W90012	MAGNUM Adaptor / Euroconus connection 12 mm	1,5 x 3/4" mm
W90014	MAGNUM Adaptor / Euroconus connection 14 mm	2 x 3/4" mm
W90016	MAGNUM Adaptor / Euroconus connection 16 mm	2 x 3/4" mm
W90018	MAGNUM Adaptor / Euroconus connection 18 mm	2 x 3/4" mm
W90020	MAGNUM Adaptor / Euroconus connection 20 mm	2 x 3/4" mm

MAGNUM Bend support

Positioning systems and accessories

90° bend support holds the heating tubes at an angle of 90° and enables you to process the tubes easily and quickly. This support is very suitable to support tubes in corners when installing in ceilings, floors or support from the manifolds of the underfloor heating system.

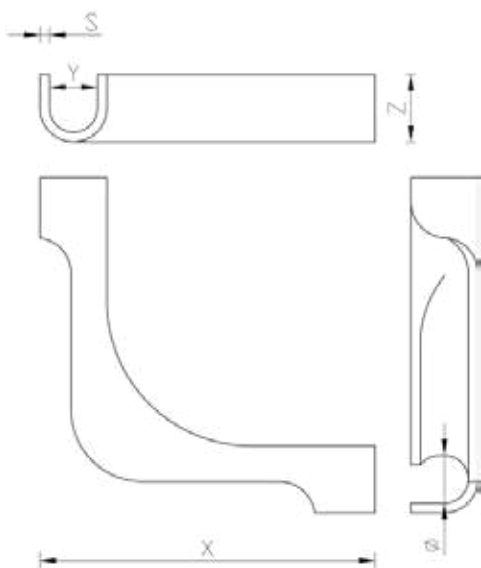

Specifications

Diameter	14 - 17 mm 18 - 20 mm
Dimensions	125 x 17 x 25 mm 140 x 20 x 39 mm
Weight	37 g 45 g
Material	PA 6 with glass fibre
Operating temperature	0°C - 65°C
Warranty	2 years
Keuring	CE



Art.nr.	Description	Dimensions
W90113	90° Bend support	Tube size ø 14 - 17 mm 2 pieces
W90114	90° Bend support	Tube size ø 18 - 20 mm 2 pieces

MAGNUM Aluminium Reflection Foil

Positioning systems and accessories

Aluminium reflection foil

Aluminium reflection foil consists of a plastic webbing and an aluminium top layer. The foil reflects heat to the screed and displaces cold via the subfloor, making it a highly effective heat conductor. The foil is designed for direct application under underfloor heating tubes and can be easily cut to size.

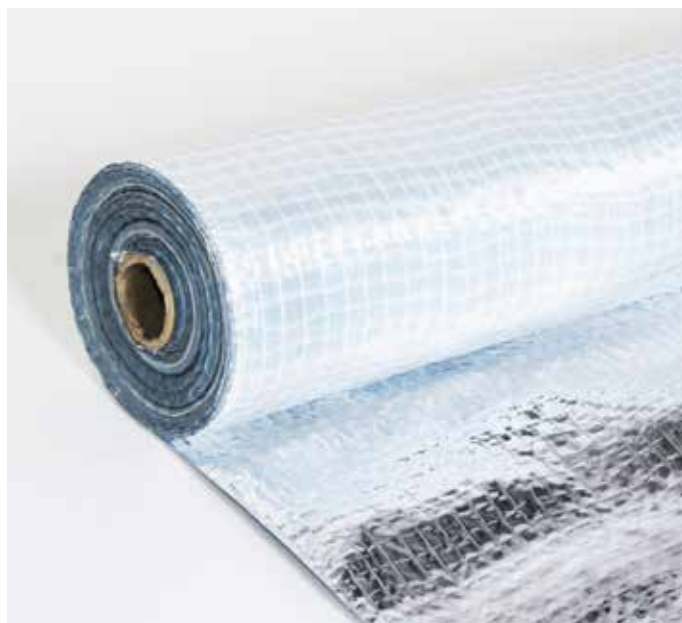

Technical details

Installation methods

- Suitable for MAGNUM Tube

Package content

- MAGNUM Aluminium reflection foil roll

Warranty

2 years warranty.

Specifications

Surface area	30 m ² - 75 m ²
Length	20 m - 50 m
Width	1,50 m
Thickness	0,20 mm
Weight per area	90 ± 25% (g/m ²)
Fire class	Class E
Tear resistance	> 100 (N)
Max. tensile strength length	> 220 (N/50mm)
Max. tensile strength width	> 150 (N/50mm)
Elongation at break length	> 12 %
Elongation at break width	> 7 %
Water vapour transmission (Sd)	50 ± 30 m
Temperature range	-30°C / 70°C
Keuring	CE



Art.nr.	Description	m ²	Dimensions
W90100	Aluminium reflection foil roll	30 m ²	20 x 1,5 m
W90101	Aluminium reflection foil roll	75 m ²	50 x 1,5 m

MAGNUM Edge insulation

Positioning systems and accessories

Edge insulation

Edge insulation should be applied when floor heating is used. This form of insulation prevents unwanted heat loss and absorbs the expansion and contraction of the floor. The edge insulation will also ensure that no cold bridges are formed.



Specifications

Roll length	25 m
Foam thickness	8 mm ± 1 mm
Foam width	150 mm ± 5 mm
Material	PE - foam
Density	18 kg/m ³ ± 5 kg/m ³
Packaging	In sturdy plastic foil
Color	Grey
Fire class	EN 13501-1:2010
Application	Conforms to all types of underfloor heating systems
Warranty	2 years
Inspection	CE



Art.nr.	Description	Dimensions
W90111	Edge insulation	25 m x 15 cm x 8 mm with flap

MAGNUM Expansion profile

Positioning systems and accessories

Expansion profile

In rooms that are larger than 40 m², it is often necessary to use expansion profiles in the floor. Also when a floor is staggered, such a joint is usually necessary. Expansion profiles prevent the screed in larger rooms from cracking due to expansion and contraction.

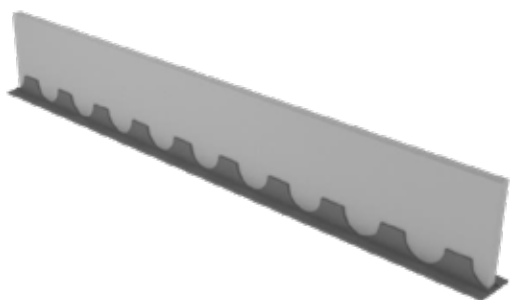

Specifications

Dimensions	2000 x 40 x 104 mm
Weight	400 g
Material	Foamed LDPE, polypropylene
Warranty	2 years
Inspection	CE

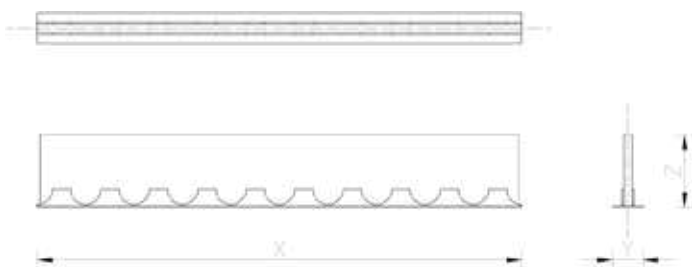

Art.nr.	Description	Dimensions
W90112	Expansion profile - Profile set with adhesive strip	5 pieces 2 m (10 m/l)

MAGNUM Tube reel

Positioning systems and accessories

Tube reel

This tube reel is made of galvanised steel and is equipped with a strong ball bearing. Furthermore, the reel is suitable for almost all common tube rolls, because the uprights of the inner core are manually adjustable. This reel is very robust and has a long service life.

The tube reel is used for quick unrolling of the tube during the installation of underfloor heating systems. The device facilitates and accelerates the work of the installer and increases the comfort of his work. The tube reel is used for quick unrolling of the tube during the installation of underfloor heating systems. Easy assembly and disassembly of the device makes it possible to move it quickly from place to place.

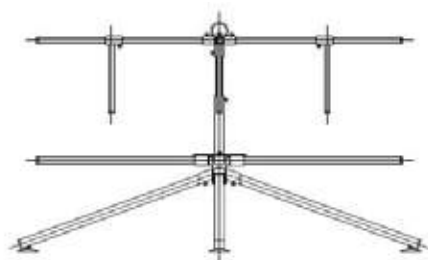

Specifications

Diameter when unfolded	1040 mm (spiral support), 1200 mm (diameter at the base)
Minimum height	170 mm
Maximum height	520 mm
Dimensions	59 x 23 x 185 cm
Weight	7,4 kg
Material	Steel
Warranty	2 years
Inspection	CE



Art.nr.	Description
W90115	Tube reel / unwinding device

MAGNUM Remote Zone Control

MAGNUM Remote Zone Control is a complete system for controlling your underfloor heating. The system consists of thermostats that can be hung in each room and a controller that is mounted near the manifold. The advanced actuators receive a signal through the controller whether they should be opened or closed depending on the temperature demand. Control the zones separately through the thermostat or through your tablet or smartphone.

MAGNUM W - Controller

The MAGNUM W - Controller receiver is specially designed to control the temperature of underfloor heating systems through the "normally closed" actuators. Each receiver can control 8 zones and can be expanded as required.



MAGNUM W - Thermostat

The MAGNUM W - Clock Thermostat ensures precise control of the room temperature. With this clock thermostat you can adjust the temperature based on a series of programmed settings that take effect at different times of the day. The thermostat is connected wirelessly to the MAGNUM W - Controller and transmits a signal when the temperature changes.



MAGNUM W - Actuators

These electrothermal actuators are used to automatically control the stopcocks. When the actuators are mounted on the taps, they automatically shut off the water supply from the boiler. As soon as there is a heat demand from the underfloor heating system, the thermostat, which is connected to the receiver, causes the actuators to open the stopcocks so that hot water from the boiler can be let into the manifold. When the correct temperature is reached, they close the stopcocks again.

Specifications

Type	Wireless thermostat
Suitable for	Water based systems
Controls	On thermostat and through app
Sensors	Room sensor
Voltage MW - C	230V – 50/60Hz
Voltage MW - T	3x AAA battery
Voltage MW - A	230V – 50/60Hz
Max. number of groups	32 per MW - C station
Temperature range	1°C - 40°C
Housing	IP21

Functions

WiFi	✓ (LAN connection required)
App	✓ iOS & Android
Voice assistant	✗
Programmable	up to 2 periods per day
Intelligence	✓
Wooden floor	✓ < 28°C
Inspection	CE



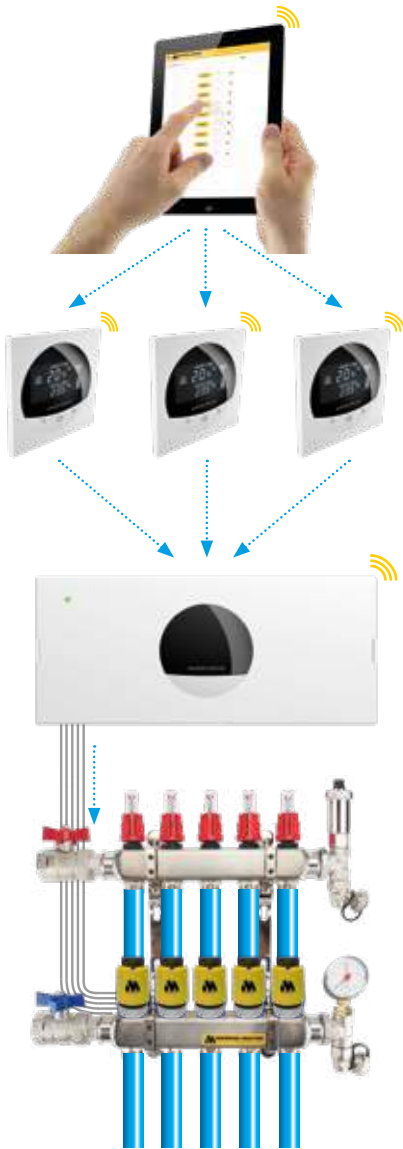

Technical details

- Wireless control through thermostat, PC, Tablet or Smartphone
- Heating and cooling mode
- Set up to 8 zones
- Merge zones easily
- Up to 32 actuators can be connected
- LAN connection necessary
- Pump control function
- Customised weekly programme
- Bus connection for Smart Home functionality
- Room/floor sensor function

Warranty

2 year warranty for MW-C, MW-T and MW-A.

Art.nr.	Description
W80001	MW - C Central 8-zone control - App control
Art.nr.	Description
W80000	MW - T Room thermostat Digital, wireless RF
Art.nr.	Description
W80003	MW - A Actuator / thermomotor 230V NC

MAGNUM H64 WiFi

H64 is a wired control system with WiFi functionality for water-based floor heating systems. The stylish H64-MT thermostat with WiFi functionality is a programmable thermostat designed to control water-based floor heating systems. An App is available in the Apple App Store and on Google Play. Within the App, you can programme and adjust settings. To control different rooms (groups), additional H64-ST slave thermostats can easily be added.



H64 Control centre + thermostat in Polar white

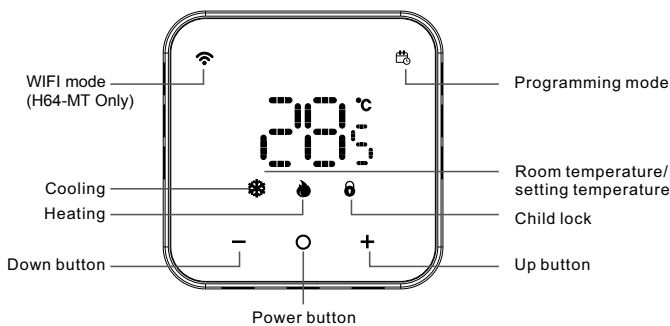

H64 Control Center + thermostat in Grafietzwart

Specifications

Type	Wired control system with WiFi
Suitable for	Waterborne systems
Operation	Touchscreen
Sensors	Room sensor
Voltage	230V - 50/60Hz
Maximum load	16A / 230V
Temperature range	+5°C / +40°C
Housing	IP21

Funcities

WiFi	✓ 2.4Ghz
App	✓ iOS & Android
Voice Assistant	Google assistant and Amazon Alexa
Programmable	up to 3 periods per day
Intelligence	✓
Wooden floor	✓ < 28°C
Open window	✓
Slow start	✓
Pilot Wire	✗
Inspection	CE



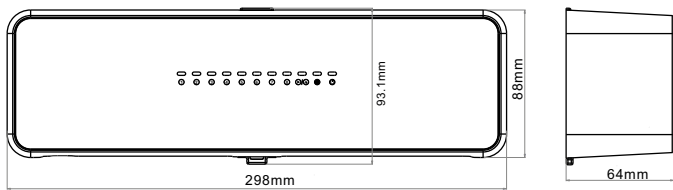

Technical details

H64-CC Control Centre

Power source 100-240VAC 50/60Hz (max. 10A)

Storage temperature and humidity -10 ~ 60 °C, 0 ~ 90% RH (non-condensing)

Operating temperature and humidity 0 ~ 50 °C, 0 ~ 80% RH (non-condensing)

Colour polar white / graphite black

Dimensions 298 x 88 x 64 mm

IP rating IP40

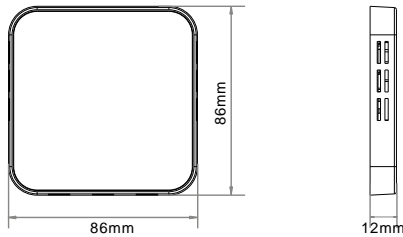

H64-MT Master WiFi Thermostat*

H64-ST Slave Thermostat

Power supply and signal input DC12 ~ 18V carrier non-polar input

Storage environment temp. & humidity 10 ~ 60°C, 0 ~ 90% RH (non-condensing)

Working environment temp. & humidity 0 ~ 50°C, 0 ~ 80% RH (non-condensing)

Display temperature range 0 ~ 50°C

Display accuracy 0.1°C Colour polar white graphite black

Dimensions (LxWxD) 86 x 86 x 12 mm

IP class IP21

* Extra on the H64-MT Master WiFi Thermostat:

WiFi frequency 2.4 GHz.

Wireless WiFi transmission distance 60 metres.

Warranty

2-year warranty on electrical operation.

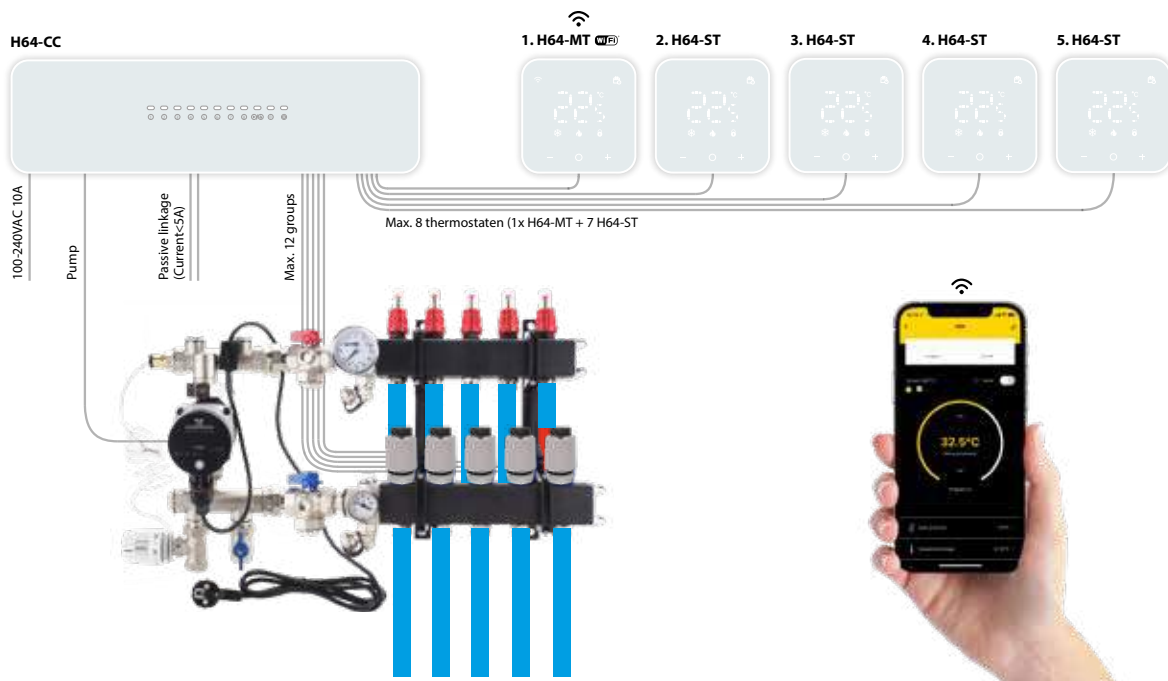

Art.nr.	Description
W81000	H64 Kit 1x H64-CC Control Center + 1x H64-MT Master WiFi Thermostat (Polar White - RAL 9010)
W81003	H64-ST Slave Thermostat (Polar White - RAL 9010)
W81004	H64 Kit 1x H64-CC Control Center + 1x H64-MT Master WiFi Thermostat (Grafiet Black - RAL 9011)
W81005	H64-ST Slave Thermostat (Grafiet Black- RAL 9011)

MAGNUM Outdoor Cable Asphalt Especially for installation in asphalt

Especially for large areas, such as loading docks or driveways for car parks, where safety must be ensured. MAGNUM Outdoor Cable can be fixed directly to the reinforcement before the sand bed, concrete or asphalt is poured.

MAGNUM Outdoor is a highly advanced system of heating cables, 2 sensor units that measure humidity in combination with the outdoor temperature and a custom-made control cabinet.

The power supply cable is uniquely connected to the resistance wire. The aluminium reinforcement jacket protects the resistance wires against mechanical damage and shields the cable against EMC (electromagnetic radiation). This has the advantage that the cable does not interfere with mobile phones, electrically operated garage doors and gates, security installations etc.

The cable is equipped with PTFE (Teflon) inner sheaths and a PVC outer sheath that is resistant to the action of chemicals.

Complete systems

A complete watertight control cabinet (IP-65) is manufactured and fitted out in proportion to the number of cables/mats and power. For larger projects, the control cabinet can be expanded to include modulating power regulators up to 50kW that prevent peak loads and also save energy. The system can be implemented in both 230V and 400V.

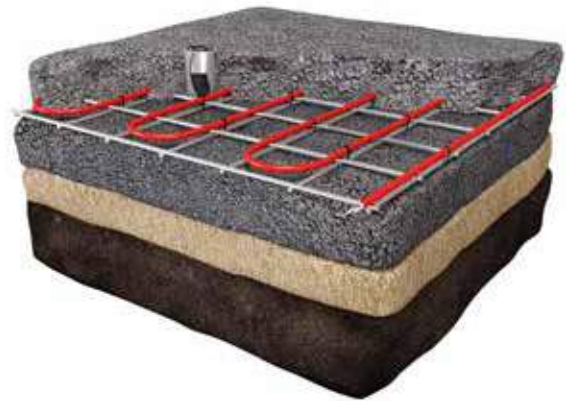

Installation in unrolled asphalt



Specifications

Sand bed + bricks	✓
Concrete	✓
Cold asphalt	✓ unrolled processing!
Asphalt < 240°C	✓ unrolled processing!
Inner jacket	PFTE (Teflon)
Outer jacket	PVC
Length of connecting wire	10 m
Power	30 Watt/m ¹
Connection voltage	230 V/50Hz
Certification	IEC 800, CE, IPX7, VDE
Warranty	10 year



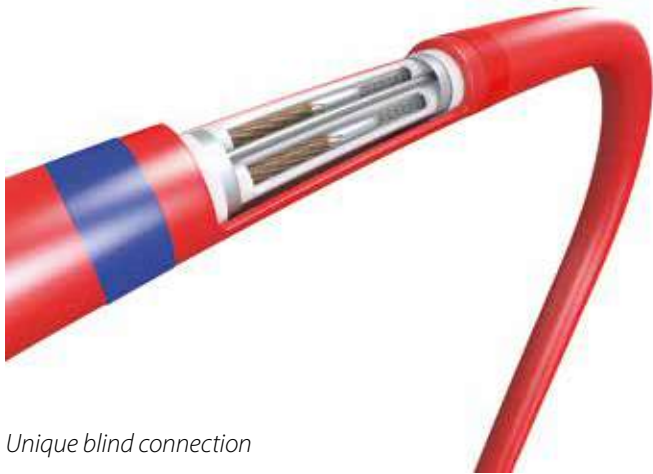

Unique blind connection

Technical details

- Power 30 Watt/m¹
- Cables available from 600 to 3400 Watt
- Connection voltage 230 V/50Hz
- Standards IEC 800 and CE
- Certification ISO 9001
- Class IPX7
- Core insulation PTFE (Teflon)
- Suitable for unrolled mastic asphalt up to 240°C

Installation methods (complete systems)

MAGNUM Outdoor systems are calculated and designed per order.

Warranty

MAGNUM Outdoor Cable has a 10 year warranty on the electrical function of the cable.



Installation in concrete

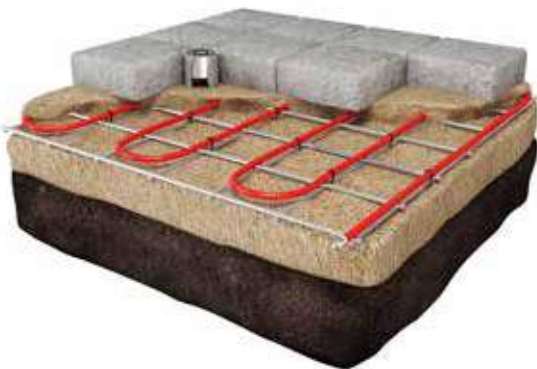

Installation in sand bed under paving stones

Art.nr.	Description	Length	Length connecting wire	Power	Volt	Amps	Ohm
125006	MAGNUM Outdoor Cable Asphalt 30W/m ¹	20 m	10 m	600 Watt	230V	2,6	88,2
125012	MAGNUM Outdoor Cable Asphalt 30W/m ¹	40 m	10 m	1200 Watt	230V	5,2	44,1
125019	MAGNUM Outdoor Cable Asphalt 30W/m ¹	63,3 m	10 m	1900 Watt	230V	8,3	27,8
125034	MAGNUM Outdoor Cable Asphalt 30W/m ¹	113,3 m	10 m	3400 Watt	230V	14,8	15,6

MAGNUM Outdoor Cable Concrete For concrete & paving

Especially for large areas, such as loading docks or driveways for car parks, where safety must be ensured. MAGNUM Outdoor Cable can be fixed directly to the reinforcement before the sand bed, concrete or asphalt is poured.

MAGNUM Outdoor is a highly advanced system of heating cables, 2 sensor units that measure humidity in combination with the outdoor temperature and a custom-made control cabinet.

The power supply cable is uniquely connected to the resistance wire. The aluminium reinforcement jacket protects the resistance wires against mechanical damage and shields the cable against EMC (electromagnetic radiation). This has the advantage that the cable does not interfere with mobile phones, electrically operated garage doors and gates, security installations etc.

The cable is equipped with XLPE inner sheaths and a PVC outer sheath that is resistant to the action of chemicals.

Complete systems

MAGNUM Outdoor installations are specially drawn and designed per order. A complete watertight control cabinet (IP-65) is manufactured and fitted out in proportion to the number of cables/mats and power. For larger projects, the control cabinet can be expanded to include modulating power regulators up to 50kW that prevent peak loads and also save energy. The system can be implemented in both 230V and 400V.



Installation in concrete

Specifications

Sand bed + bricks	V
Concrete	V
Cold asphalt	X
Asphalt < 240°C	X
Inner jacket	XLPE
Outer jacket	PVC
Length of connecting wire	4 m
Power	30 Watt/m ¹
Connection voltage	230 V/50Hz
Certification	IEC 800, CE, VDE, IPX7
Warranty	10 year





Unique blind connection!

Technical details

- Power 30 Watt/m¹
- Cables available from 300 to 4200 Watt
- Connection voltage 230 V/50Hz
- Standards IEC 800 and CE
- Certification ISO 9001
- Class IPX7
- Core insulation XLPE

Installation methods (complete systems)

MAGNUM Outdoor systems are calculated and designed per order.

Warranty

MAGNUM Outdoor Cable has a 10 year warranty on the electrical function of the cable.



Installation in sand bed under paving stones

Art.nr.	Description	Length	Length connecting wire	Power	Volt	Amps	Ohm
120308	MAGNUM Outdoor Cable Concrete 30W/m ¹	10 m	4 m	300 Watt	230V	1,3	176
120458	MAGNUM Outdoor Cable Concrete 30W/m ¹	15 m	4 m	450 Watt	230V	2,0	118
120608	MAGNUM Outdoor Cable Concrete 30W/m ¹	20 m	4 m	600 Watt	230V	2,6	88
120758	MAGNUM Outdoor Cable Concrete 30W/m ¹	25 m	4 m	750 Watt	230V	3,3	71
120908	MAGNUM Outdoor Cable Concrete 30W/m ¹	30 m	4 m	900 Watt	230V	3,9	59
121208	MAGNUM Outdoor Cable Concrete 30W/m ¹	40 m	4 m	1200 Watt	230V	5,2	44
121508	MAGNUM Outdoor Cable Concrete 30W/m ¹	50 m	4 m	1500 Watt	230V	6,5	35
121808	MAGNUM Outdoor Cable Concrete 30W/m ¹	60 m	4 m	1800 Watt	230V	7,8	29
122108	MAGNUM Outdoor Cable Concrete 30W/m ¹	70 m	4 m	2100 Watt	230V	9,1	25
122408	MAGNUM Outdoor Cable Concrete 30W/m ¹	80 m	4 m	2400 Watt	230V	10,4	22
123008	MAGNUM Outdoor Cable Concrete 30W/m ¹	100 m	4 m	3000 Watt	230V	13,0	18
123408	MAGNUM Outdoor Cable Concrete 30W/m ¹	113 m	4 m	3400 Watt	230V	14,8	16
123608	MAGNUM Outdoor Cable Concrete 30W/m ¹	120 m	4 m	3600 Watt	230V	15,7	15
124208	MAGNUM Outdoor Cable Concrete 30W/m ¹	140 m	4 m	4200 Watt	230V	18,3	13

MAGNUM Outdoor Mat

For installation in asphalt and concrete

This mat has been specially developed for heating footpaths and driving tracks. The heating mat is easy to unroll, cut and fold for simple and quick installation.

MAGNUM Outdoor Mat is a highly advanced system of heating mats, 2 sensor units that measure humidity in combination with the outdoor temperature and a custom-made control cabinet.

The power supply cable is uniquely connected to the resistance wire. The aluminium reinforcement jacket protects the resistance wires against mechanical damage and shields the cable against EMC (electromagnetic radiation). This has the advantage that the cable does not interfere with mobile phones, electrically operated garage doors and gates, security installations etc.

The cable is equipped with PTFE (Teflon) inner sheaths and a PVC outer sheath that is resistant to the action of chemicals.

Complete systems

MAGNUM Outdoor installations are specially drawn and designed per order. A complete watertight control cabinet (IP-65) is manufactured and fitted out in proportion to the number of cables/mats and power. For larger projects, the control cabinet can be expanded to include modulating power regulators up to 50kW that prevent peak loads and also save energy. The system can be implemented in both 230V and 400V.



Installation in unrolled asphalt

Specifications

Sand bed + bricks	✓
Concrete	✓
Cold asphalt	✓ unrolled processing!
Asphalt < 240°C	✓ unrolled processing!
Inner jacket	PFTE (Teflon)
Outer jacket	PVC
Length of connecting wire	10 m
Power	30 Watt/m ¹
Connection voltage	230 V/50Hz
Certification	IEC 800, CE, VDE , IPX7
Warranty	10 year





Unique blind connection

Technical details

- Power 300 Watt/m²
- Dimensions 2, 5, 8 & 10 m²
- Connection voltage 230 V/50Hz
- Standards IEC 800 and CE
- Certification VDE
- Class IPX7
- Core insulation PTFE (Teflon)
- Suitable for unrolled mastic asphalt up to 240°C

Installation methods (complete systems)

MAGNUM Outdoor systems are calculated and designed per order.

Warranty

MAGNUM Outdoor Mat has a 10 year warranty on the electrical function of the cable.



Installation in concrete



Installation under paving stones

Art.nr.	Description	m ²	Dimensions	Power	Volt	Amps	Ohm
126002	MAGNUM Outdoor Mat	2 m ²	0,5 x 4 m	600 Watt	230V	2,6	88,2
126005	MAGNUM Outdoor Mat	5 m ²	0,5 x 10 m	1500 Watt	230V	6,5	35,3
126008	MAGNUM Outdoor Mat	8 m ²	0,5 x 16 m	2400 Watt	230V	10,4	22
126010	MAGNUM Outdoor Mat	10 m ²	0,5 x 20 m	3000 Watt	230V	13	17,6

MAGNUM Outdoor Control Control cabinets

Complete watertight control cabinets manufactured and fitted according to the number of cables/mats and power. The system can be implemented in both 230V and 400V.

Connection box

The control cabinets can be assembled custom-made for each project. The standard version is equipped (according to NEN1010) with the necessary waterproof cable entries, magnetic circuits (relays), circuit breakers, earth leakage switches, terminal strips for easy connection of power and heating cables and the special outdoor road sensor units. For this, the diagram shown in the switch box must be followed.



Specifications

ETO2-4550 DIN-rail	Thermostat 0°C / +5°C 230V
2x ETOG-56 Sensorunits	Humidity & Temperature
Potential-free contacts	3 x 16 Amps
Required solenoid circuits (relays)	230V/400V
Required installation circuit breakers	16 Amps
Connection terminals	for mounting power cables
Indicator lights	
Warranty	2 year



Art.nr.	Description	kW	Cabinet dimensions	Unit	
900004	MAGNUM Outdoor control cabinet	3,6 kW	430 x 310 x 160 mm	units/1	incl. ETO2-4550 DIN-rail thermostat and 2x ETOG-56 sensor units
900010	MAGNUM Outdoor control cabinet	10 kW	500 x 400 x 200 mm	units/1	incl. ETO2-4550 DIN-rail thermostat and 2x ETOG-56 sensor units
900020	MAGNUM Outdoor control cabinet	20 kW	500 x 400 x 200 mm	units/1	incl. ETO2-4550 DIN-rail thermostat and 2x ETOG-56 sensor units
900030	MAGNUM Outdoor control cabinet	30 kW	700 x 520 x 253 mm	units/1	incl. ETO2-4550 DIN-rail thermostat and 2x ETOG-56 sensor units
900040	MAGNUM Outdoor control cabinet	40 kW	700 x 520 x 253 mm	units/1	incl. ETO2-4550 DIN-rail thermostat and 2x ETOG-56 sensor units
900050	MAGNUM Outdoor control cabinet	50 kW	700 x 520 x 253 mm	units/1	incl. ETO2-4550 DIN-rail thermostat and 2x ETOG-56 sensor units

MAGNUM Ideal Frost-Free Ribbon

Ideal Frost-Free Ribbon

In many situations, outdoor taps and pipes are shut off in winter to prevent freezing and damage. MAGNUM offers a much simpler solution: with MAGNUM Ideal frost-free ribbon, frozen and burst water pipes are definitely a thing of the past! The MAGNUM Ideal range has been specially designed to keep (water) pipes, taps, drains, etc. frost-free.

Freezing problems can easily be prevented by installing a frost-free ribbon, ready to plug in and with automatic thermostat, along the pipe. Then, fitted with pipe insulation, this application not only provides safety, but also prevents additional and unnecessary costs from water damage. When installed on plastic piping, it must first be completely wrapped in aluminium tape before the cable can be applied.

MAGNUM Ideal frost-free ribbons are ready to use (with a 2 metre long connecting cable and earthed plug) and equipped with temperature control through bi-metal. MAGNUM Ideal frost-free ribbons are available in lengths from 1 to 48 metres. The ribbon switches on at a temperature below +5°C and switches off automatically if the temperature of the pipe exceeds +13°C.

The heating ribbon must never be placed directly on a PVC pipe, the PVC pipe must first be covered with aluminium tape for proper heat conduction.



Specifications

System type	Outdoor
Dimensions	1 m to 48 m
Power	10 Watt per metre
Connection voltage	230 V/50Hz
Certification	VDE, CE, IPX7
Warranty	2 year





Technical details

- Power 10 Watt per metre length / 230V
- Connection cable 2 metres with earthed plug
- Class IPX7

Installation methods

MAGNUM Ideal can be easily attached to the pipes using aluminium tape or plastic ties (tiewraps). When installed on plastic piping, it should first be completely wrapped with aluminium tape before the cable can be applied. MAGNUM Ideal should always be used in combination with (polyethylene) pipe insulation with a minimum wall thickness of 10 mm. This for optimal protection and insulation, so that an energy-efficient operation is guaranteed.

Package content

- Ready to switch heating cable with built-in, bi-metal thermostat.
- Installation instructions
- PVC-Tape

Warranty

MAGNUM Ideal frost-free ribbon has a 2 year guarantee on the electrical function of the ribbon.

Calculate the required cable length here:

Max. pipe diameter	15mm	20mm	25mm	30mm	40mm	50mm	100mm
Application method	Protection factor of the water supply:						
Linear (along pipe)	-30 °C	-30 °C	-25 °C	-20 °C	-15 °C	-10 °C	-5 °C
10 windings per m.	--	--	-30 °C	-30 °C	-25 °C	-25 °C	-20 °C
20 windings per m.	--	--	--	--	-30 °C	-30 °C	-30 °C
Calculate the cable	Length of pipe times:						
10 windings per m (x)	1,25	1,50	1,75	2	2,25	2,5	4
20 windings per m (x)	2	2,25	2,50	2,75	3,25	4	8

Art.nr.	Description	Length	Power	Volt
155001	MAGNUM Ideal frost-free ribbon	1 m	10 Watt	230V
155002	MAGNUM Ideal frost-free ribbon	2 m	20 Watt	230V
155004	MAGNUM Ideal frost-free ribbon	4 m	40 Watt	230V
155006	MAGNUM Ideal frost-free ribbon	6 m	60 Watt	230V
155008	MAGNUM Ideal frost-free ribbon	8 m	80 Watt	230V
155010	MAGNUM Ideal frost-free ribbon	10 m	100 Watt	230V
155014	MAGNUM Ideal frost-free ribbon	14 m	140 Watt	230V
155018	MAGNUM Ideal frost-free ribbon	18 m	180 Watt	230V
155022	MAGNUM Ideal frost-free ribbon	22 m	220 Watt	230V
155026	MAGNUM Ideal frost-free ribbon	26 m	260 Watt	230V
155030	MAGNUM Ideal frost-free ribbon	30 m	300 Watt	230V
155034	MAGNUM Ideal frost-free ribbon	34 m	340 Watt	230V
155040	MAGNUM Ideal frost-free ribbon	40 m	400 Watt	230V
155048	MAGNUM Ideal frost-free ribbon	48 m	480 Watt	230V

MAGNUM Trace Regular

Self regulating heating ribbon < 85°C

MAGNUM Trace Regular - MTR is an industrial, self-regulating heating ribbon that can be used for protection against freezing or for temperature regulation in tubes and on vehicles up to 85°C. Suitable for use in non-risky and corrosive areas. It can be cut to size on site to fit the pipes exactly, without the need for a complicated design. Due to the self-regulating properties, safety and reliability are increased. The MTR does not overheat and does not burn up, even when it overlaps itself. The current flow regulates itself according to the temperature in the tube. MTR is available with a stainless, thermoplastic outer jacket.

Applications

Cold water pipelines
Drains
Sprinkler systems

Additional Information

The amount of heat loss depends on the diameter of the pipeline, ambient temperature and flow rate of the fluid. Additional insulation is recommended. The use of a temperature controller reduces energy consumption.

For a heat loss calculation and applicable cable, please contact the calculation department of MAGNUM Heating.

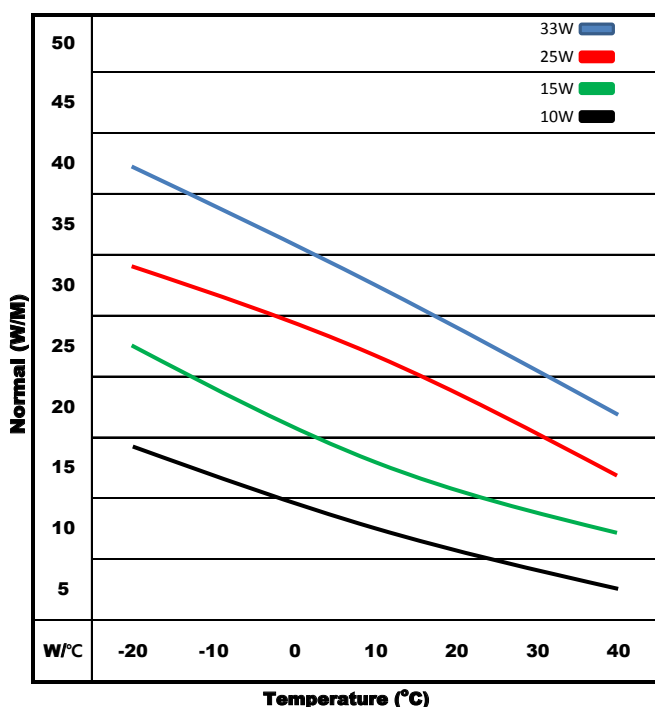

Specifications

Max. temperature	Without voltage 85°C With voltage 65°C
Min. operating temperature	-30°C
Max. resistance	18,2 Ohm/km
Nominal voltage	230V
Outer jacket	Tinned copper
Coating	TPE
Water resistant	100%
Dimensions	13 x 6,8 mm
Min. bending radius	25 mm
Weight	12 kg/100 m
T-classification 10,15,25 W/m	T6
T-classification 33 W/m	T5
Color	Grey
Certification	10MTR & 25MTR: CE /RU 15MTR & 33MTR: CE/RU/ FM/EX, according to DIN EN 62395-1, VDE
Warranty	2 year





Technical details

- Max. temperature Without voltage 85°C
With voltage 65°C
- Min. operating temperature -30°C
- Max. resistance 18,2 Ohm/km
- Nominal voltage 230V
- Outer jacket Tinned copper
- Coating TPE
- Water resistant 100%
- Dimensions 13 x 6,8 mm
- Min. bending radius 25 mm
- Weight 12 kg/100 m
- T-classification 10, 15, 25 W/m T6
- T-classification 33 W/m T5
- Color Grey
- Certification 10MTR & 25MTR: CE /RU
15MTR & 33MTR: CE/RU/FM/
EX according to DIN
EN 62395-1
- Warranty 2 year

Installation methods

- Check whether all necessary materials and tools are present at the construction site.
- Inspect the pipe, gutter or surface to be heated, deburring any unevenness and sharp edges or removing the sharp edges with tape.
- Remove any unevenness and sharp edges or remove the sharp edges with tape.
- Clean and dry gutters before laying the heating cable.
- Allow painted and coated pipes and surfaces to become completely dry before commencing installation.
- In the case of a plastic pipe, first wrap it with aluminium tape

Max. recommended cable length at 230V using Type-C relays:

Categorie Reference	Switch 16A	20A	230V 20A	30A
10MTR	+10°C	205 m	-	-
	-15°C	140 m	186 m	195 m
	-25°C	123 m	165 m	195 m
15MTR	+10°C	145 m	162 m	-
	-15°C	93 m	125 m	160 m
	-25°C	82 m	111 m	160 m
25MTR	+10°C	88 m	117 m	126 m
	-15°C	60 m	75 m	117 m
	-25°C	50 m	70 m	105 m
33MTR	+10°C	70 m	90 m	108 m
	-15°C	50 m	65 m	95 m
	-25°C	45 m	58 m	85 m

ATTENTION: Heating cables in combination with drinking water pipelines must be thermostatically controlled at all times.

Art.nr.	Description	Length	Power per metre	Volt
151010	MAGNUM Trace Regular	10 m	10 Watt @ 10°C	230V
151015	MAGNUM Trace Regular	15 m	15 Watt @ 10°C	230V
151025	MAGNUM Trace Regular	25 m	25 Watt @ 10°C	230V
151033	MAGNUM Trace Regular	33 m	33 Watt @ 10°C	230V

MAGNUM Trace Micro

Self regulating heating ribbon < 65°C

MAGNUM Trace Micro - MTM is an industrial, self-regulating heating ribbon that can be used for protection against freezing or for temperature regulation in tubes and on vehicles. It is particularly suitable for use on pipes and instruments with small diameters. It can also be cut to size on site, so that it fits exactly on the pipes, without having to take complicated design into account. Due to the self regulating properties, safety and reliability are increased. The MTM does not overheat or burn, even when it overlaps itself. The current regulates itself according to the temperature in the tube. MTM is available with a stainless, thermoplastic outer jacket and, if greater corrosion resistance is required, with a fluoropolymer outer jacket (MTM-Fluoropolymer).

Applications

Cold water pipelines
Drains
Sprinkler systems

Additional Information

The amount of heat loss depends on the diameter of the pipeline, ambient temperature and flow rate of the fluid. Additional insulation is recommended. The use of a temperature controller reduces energy consumption.

For a heat loss calculation and applicable cable, please contact the calculation department of MAGNUM Heating.



Specifications

Max. temperature	65°C
Min. operating temperature	-30°C
Max. resistance	18 Ohm/km
Nominal voltage	230V
Outer jacket	Tinned copper
Coating	Thermoplastic or Fluoropolymer
Water resistant	100%
Dimensions	8 x 5 mm
Min. bending radius	25 mm
Weight	7 kg/100 m
Color	MTM 11 & 17 Watt (Red) MTM 11 & 17 Watt Fluoropolymer (Blue)
Certification	CE /RU, according to DIN EN 62395-1, VDE
Warranty	2 year

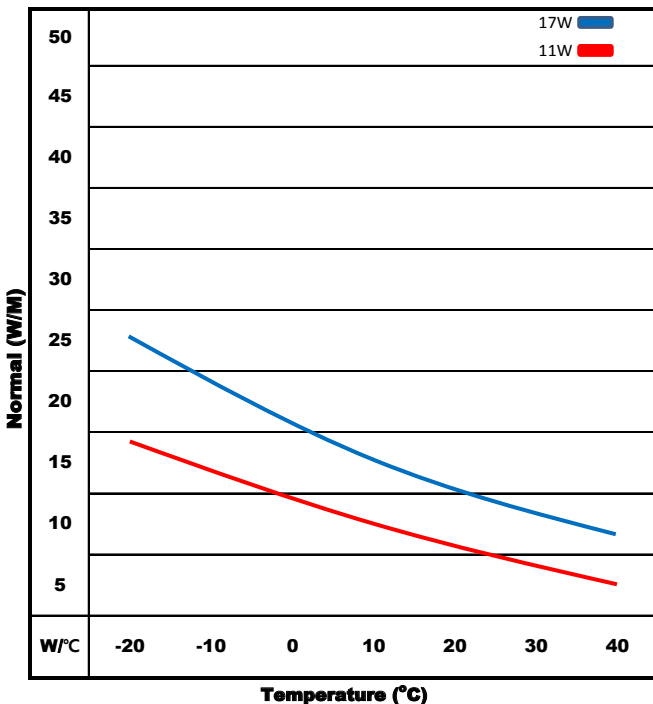

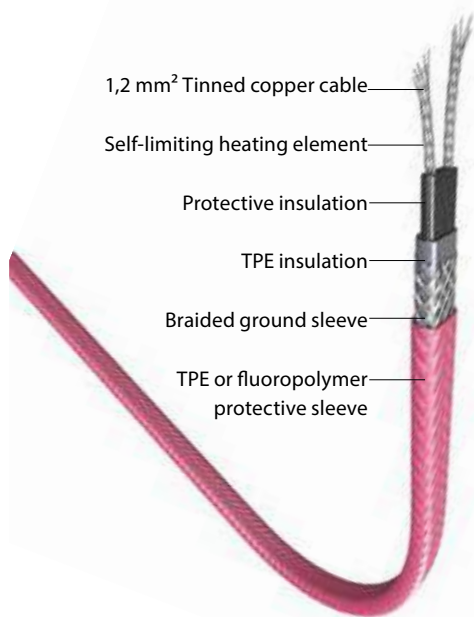

Technical details

- Max. temperature 65°C
- Min. operating temperature -30°C
- Max. resistance 18 Ohm/km
- Nominal voltage 230V
- Outer jacket Tinned copper
- Coating Thermoplastic or Fluoropolymer
- Water resistant 100%
- Dimensions 8 x 5 mm
- Min. bending radius 25 mm
- Weight 7 kg/100 m
- Color MTM 11 & 17 Watt (Red)
MTM 11 & 17 Watt Fluoropolymer (Blue)
- Certification CE /RU, according to DIN EN 62395-1
- Warranty 2 year

Installation methods

- Check whether all necessary materials and tools are present at the construction site.
- Inspect the pipe, gutter or surface to be heated, deburring any unevenness and sharp edges or removing the sharp edges with tape.
- Remove any unevenness and sharp edges or remove the sharp edges with tape.
- Clean and dry gutters before laying the heating cable.
- Allow painted and coated pipes and surfaces to become completely dry before commencing installation.
- In the case of a plastic pipe, first wrap it with aluminium tape

Max. recommended cable length at 230V using Type-C relays:

Categorie Referentie	Switch Temp.	230V		
		6A	10A	16A
11MTM	5°C	70 m	100 m	110 m
	0°C	65 m	95 m	105 m
	-20°C	44 m	77 m	90 m
	-30°C	38 m	67 m	80 m
17MTM	5°C	39 m	60 m	70 m
	0°C	37 m	58 m	65 m
	-20°C	25 m	44 m	50 m
	-30°C	23 m	41 m	47 m

ATTENTION: Heating cables in combination with drinking water pipelines must be thermostatically controlled at all times.



Fluoropolymer

Art.nr.	Description	Length	Power per metre	Volt
150211	MAGNUM Trace Micro 11	Per metre	11 Watt @ 10°C	230V
150411	MAGNUM Trace Micro 11	Roll 25 metres	11 Watt @ 10°C	230V
150511	MAGNUM Trace Micro 11	Roll 50 metres	11 Watt @ 10°C	230V
150611	MAGNUM Trace Micro 11	Roll 100 metres	11 Watt @ 10°C	230V
150217	MAGNUM Trace Micro 17	Per metre	17 Watt @ 10°C	230V
150417	MAGNUM Trace Micro 17	Roll 25 metres	17 Watt @ 10°C	230V
150517	MAGNUM Trace Micro 17	Roll 50 metres	17 Watt @ 10°C	230V
150617	MAGNUM Trace Micro 17	Roll 100 metres	17 Watt @ 10°C	230V

Art.nr.	Description	Length	Power per metre	Volt
150311	MAGNUM Trace Micro Fluoropolymer	Per metre	11 Watt @ 10°C	230V
150317	MAGNUM Trace Micro Fluoropolymer	Per metre	17 Watt @ 10°C	230V

MAGNUM Trace Micro Plug & Go

Self regulating heating ribbon < 65°C

MAGNUM Trace Micro Plug & Go is an industrial self-regulating heating ribbon, which can be used for frost protection or maintaining the temperature of pipes up to 65°C. For use in non-hazardous, hazardous and corrosive areas. The self-regulating property of MAGNUM Tracing cables prevents overheating or burning even when heating cables are overlapped. The power regulates itself in response to the ambient temperature. The conductive polymer core automatically releases the required heat at any point along the pipe without the use of a thermostat.

Applications

Cold water pipelines
Drains
Sprinkler systems

Additional Information

The amount of heat loss depends on the diameter of the pipeline, ambient temperature and flow rate of the fluid. Additional insulation is recommended. The use of a temperature controller reduces energy consumption.

For a heat loss calculation and applicable cable, please contact the calculation department of MAGNUM Heating.



Specifications

Max. temperature	65°C
Min. operating temperature	-30°C
Max. resistance	18 Ohm/km
Nominal voltage	230V
Outer jacket	Tinned copper
Coating	Thermoplastic or Fluoropolymer
Water resistant	100%
Dimensions	8 x 5 mm
Min. bending radius	25 mm
Weight	7 kg/100 m
Color	MTM 11 & 17 Watt (Red) MTM 11 & 17 Watt Fluoropolymer (Blue)
Certification	CE /RU, according to DIN EN 62395-1, VDE
Warranty	2 year





Technical details

- Ready to connect heating elements including connectors
- Power 11 Watt per metre @ 10°C 230V
- IP67 connection
- Max. temperature 65°C
- Min. operating temperature -30°C
- Max. resistance 18 Ohm/km
- Nominal voltage 230V
- Outer jacket Tinned copper
- Coating Thermoplastic or Fluoropolymer
- Water resistant 100%
- Dimensions 8 x 5 mm
- Min. bending radius 25 mm
- Weight 7 kg/100 m
- Color MTM 11 & 17 Watt (Red)
MTM 11 & 17 Watt
Fluoropolymer (Blue)
- Certification CE /RU, according to
DIN EN 62395-1
- Warranty 2 year

Connection cable

- Grounded connection cable with earth
- Including connector and end cap
- Available with or without thermostat
- Thermostat switches on at < 5°C

Installation methods

- Check whether all necessary materials and tools are present at the construction site.
- Inspect the pipe, gutter or surface to be heated, deburring any unevenness and sharp edges or removing the sharp edges with tape.
- Remove any unevenness and sharp edges or remove the sharp edges with tape.
- Clean and dry gutters before laying the heating cable.
- Allow painted and coated pipes and surfaces to become completely dry before commencing installation.
- In the case of a plastic pipe, first wrap it with aluminium tape

Max. recommended cable length at 230V using Type-C relays:

Categorie Referentie	Switch Temp.	6A	230V 10A	16A
11MTM	5°C	70 m	100 m	110 m
	0°C	65 m	95 m	105 m
	-20°C	44 m	77 m	90 m
	-30°C	38 m	67 m	80 m

ATTENTION: Heating cables in combination with drinking water pipelines must be thermostatically controlled at all times.

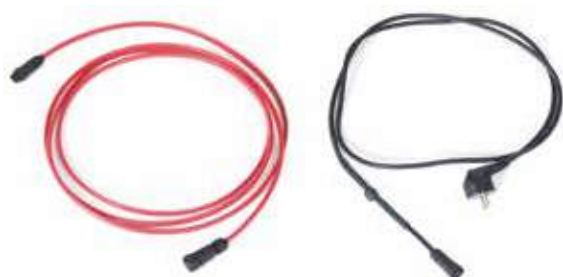

Art.nr.	Description	Length	Power	Volt
159711A	MAGNUM Trace Micro Plug & Go 1	1 m	11 Watt @ 10°C	230V
159703	MAGNUM Trace Micro Plug & Go 3	3 m	33 Watt @ 10°C	230V
159705	MAGNUM Trace Micro Plug & Go 5	5 m	55 Watt @ 10°C	230V
159709	MAGNUM Trace Micro Plug & Go 9	9 m	99 Watt @ 10°C	230V
159715	MAGNUM Trace Micro Plug & Go 15	15 m	165 Watt @ 10°C	230V
159722	MAGNUM Trace Micro Plug & Go 22	22 m	242 Watt @ 10°C	230V

Art.nr.	Options
159701	Connecting cable 2 metres without thermostat incl. connector and end cap
159702	Connection cable 2 metres with thermostat incl. connector and end cap. Switching temperature: < 5°C

MAGNUM Trace Water

Self-regulating heating ribbon for water pipes < 65°C

MAGNUM Trace Water (MTW) is a self-regulating heating ribbon that can be used for frost protection in indoor and outdoor water pipes. It can be cut to size on-site to fit the pipework exactly, without the need for complex design. The self-regulating properties increase safety and reliability by adjusting the heat output to the temperature in the pipes.

MAGNUM Trace Water is equipped with a polyolefin outer casing that meets all requirements and can therefore be used safely in combination with drinking water.

Additional Information

The amount of heat loss depends on the diameter of the pipeline, ambient temperature and flow rate of the fluid. Additional insulation is recommended. The use of a temperature controller reduces energy consumption.

For a heat loss calculation and applicable cable, please contact the calculation department of MAGNUM Heating.



Trace Water Set

Specifications

Max. temperature	Without voltage 65°C
Min. operating temperature	-40°C
Max. resistance	18 Ohm/km
Max. cable length	100 m with 16A circuit breaker
Nominal voltage	230V
Outer jacket	Tinned copper
Coating	Polyolefin
Water resistant	100%
Dimensions	8 x 5,9 mm
Min. bending radius	25 mm
Weight	7,3 kg/100 m
Color	Violet
Certification	CE according to DIN EN 62395-1, VDE
Warranty	2 year



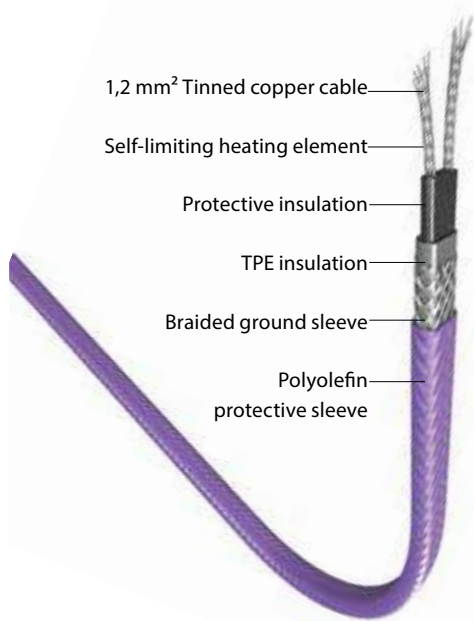

Technical details

• Max. temperature	Without voltage 65°C
• Min. operating temperature	- 40°C
• Max. resistance	18 Ohm/km
• Max. cable length	100 m with 16A circuit breaker
• Nominal voltage	230V
• Outer jacket	Tinned copper
• Coating	Polyolefin
• Water resistant	100%
• Dimensions	8 x 5,9 mm
• Min. bending radius	25 mm
• Weight	7,3 kg/100 m
• Color	Violet
• Certification	CE according to DIN EN 62395-1
• Warranty	2 year

Installation methods

- Check whether all necessary materials and tools are present at the construction site.
- Inspect the pipe, gutter or surface to be heated, deburring any unevenness and sharp edges or removing the sharp edges with tape.
- Remove any unevenness and sharp edges or remove the sharp edges with tape.
- Clean and dry gutters before laying the heating cable.
- Allow painted and coated pipes and surfaces to become completely dry before commencing installation.

Set contents

Ready-to-use heating elements incl.:

- MTW self-regulating cable with end seal
- 3/4-inch copper cable conductor/conduit connection
- Connection set for power supply

ATTENTION: Heating cables in combination with drinking water pipes must be thermostatically controlled at all times.

Complete installation of an MTW Kit:

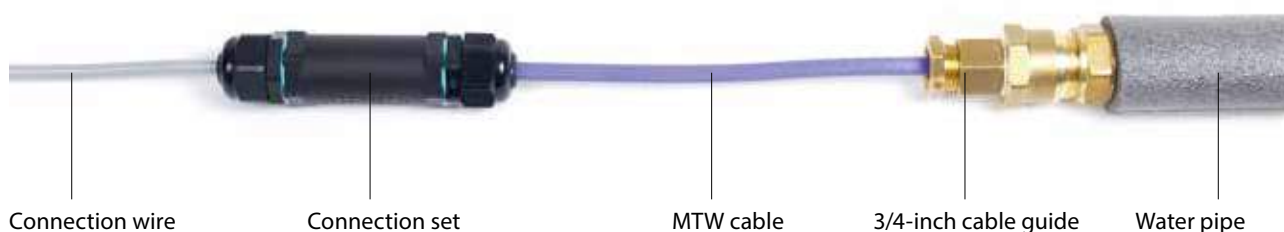

Art.nr.	Description	Length	Power per metre	Volt
159000	MAGNUM Trace Water	Per metre	10 Watt @ 10°C	230V
Art.nr.	Description	Length	Power per metre	Volt
159002	MAGNUM Trace Water Set	2 m	20 Watt @ 10°C	230V
159003	MAGNUM Trace Water Set	3 m	30 Watt @ 10°C	230V
159004	MAGNUM Trace Water Set	4 m	40 Watt @ 10°C	230V
159005	MAGNUM Trace Water Set	5 m	50 Watt @ 10°C	230V
159006	MAGNUM Trace Water Set	6 m	60 Watt @ 10°C	230V
159008	MAGNUM Trace Water Set	8 m	80 Watt @ 10°C	230V
159010	MAGNUM Trace Water Set	10 m	100 Watt @ 10°C	230V
159013	MAGNUM Trace Water Set	13 m	130 Watt @ 10°C	230V
159020	MAGNUM Trace Water Set	20 m	200 Watt @ 10°C	230V
159025	MAGNUM Trace Water Set	25 m	250 Watt @ 10°C	230V

MAGNUM Trace Hot Water

Self-regulating heating ribbon for water pipes < 85°C

MAGNUM Trace Hot Water (MTHW) is a self-regulating heating ribbon designed to compensate for heat loss from hot water distribution systems.

If the hot tap is not used continuously, the water in the distribution pipes cools and is usually lost before the hot water from the source reaches the tap.

This MTHW does not overheat or burn, even when it overlaps itself. The current regulates itself according to the temperature in the tube. The self-regulating properties increase safety and reliability. By applying it to the pipes (under the thermal insulation), heat loss is eliminated and the water remains at the desired temperature.

Installing MTHW is quick and easy, and the cable can be cut to the exact length of the tubes. No special skills or tools are required. The supplies for terminating, splicing and connecting to power are available separately.

Additional Information

The amount of heat loss depends on the diameter of the pipeline, ambient temperature and flow rate of the fluid. Additional insulation is recommended. The use of a temperature controller reduces energy consumption.

For a heat loss calculation and applicable cable, please contact the calculation department of MAGNUM Heating.



Specifications

Max. temperature	Without voltage 85°C With voltage 65°C
Min. operating temperature	-30°C
Max. resistance	18,2 Ohm/km
Nominal voltage	230V (120V on request)
Outer jacket	Tinned copper
Coating	TPE
Water resistant	100%
Dimensions	13 x 6,8 mm
Min. bending radius	25 mm
Weight	12 kg/100 m
Color	Brown
Certification	CE according to DIN EN 62395-1, VDE
Warranty	2 year



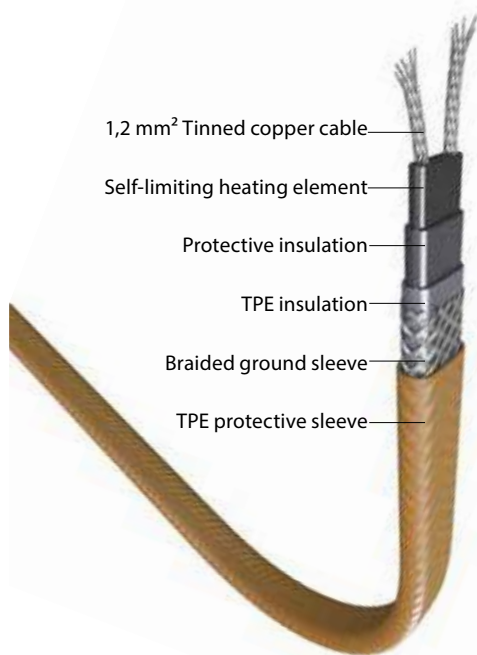

Technical details

- Max. temperature Without voltage 85°C
With voltage 65°C
- Min. operating temperature -30°C
- Max. resistance 18,2 Ohm/km
- Nominal voltage 230V (120V on request)
- Outer jacket Tinned copper
- Coating TPE
- Water resistant 100%
- Dimensions 13 x 6,8 mm
- Min. bending radius 25 mm
- Weight 12 kg/100 m
- Color Brown
- Certification CE according to DIN EN 62395-1
- Warranty 2 year

Installation methods

- Check whether all necessary materials and tools are present at the construction site.
- Inspect the pipe, gutter or surface to be heated, deburring any unevenness and sharp edges or removing the sharp edges with tape.
- Remove any unevenness and sharp edges or remove the sharp edges with tape.
- Clean and dry gutters before laying the heating cable.
- Allow painted and coated pipes and surfaces to become completely dry before commencing installation.

ATTENTION: Heating cables in combination with drinking water pipes must be thermostatically controlled at all times.

Maximum length (m) vs. size of circuit break:

Category Referentie	Switch Temp.	6A	230V 10A	16A	20A
MTHW-9	18°C	56 m	92 m	128 m	-
	0°C	38 m	64 m	102 m	128 m
MTHW-12	18°C	34 m	56 m	90 m	94 m
	0°C	24 m	40 m	64 m	80 m

For use with Type C Circuit Breakers to BS EN60898:1991.

Recommended insulation thickness (mm):

Category Reference	Preserve Temp.	Tube 15 mm	Tube 22 mm	Tube 28 mm	Tube 35 mm	Tube 42 mm	Tube 54 mm
MTHW-9	60°C	25	30	40	50	60	75
	55°C	20	25	30	40	50	60
	50°C	15	20	25	30	40	50
MTHW-12	45-70°C	30	40	50	60	75	75

These figures are based on the thermal insulation with a K-value of 0.038W/mK at an average temperature of 36°C.

Art.nr.	Description	Power per metre	Volt
159555	MAGNUM Trace Hot Water - per metre	9 Watt @ 55°C	230V
159565	MAGNUM Trace Hot Water - per metre	12 Watt @ 65°C	230V

MAGNUM Trace Gutter Heat

Self-regulating heating ribbon for gutters < 85°C

MAGNUM Trace Gutter Heat (MTGH-Kit) is a self-regulating heating ribbon specifically designed to prevent snow and ice formation on roofs, in gutters and downspouts. Even in snow and icy water, the cable functions at full power. As the snow melts and the water flows away, the MTGH Kit regulates itself to half power as it gets drier; the warmer it gets, the more it reduces its output. This cable can be cut to length during installation. The MTGH-Kit is a self-regulating cable, which prevents overheating. It can even be installed directly into plastic gutters, and with its black, rustproof and UV-resistant outer jacket, it is resilient and reliable.

The MTGH kit is quick and easy to install and requires no special skills or tools. Components are available for terminating, splitting and connecting.

Additional Information

The use of an additional temperature controller is recommended. A controller that measures the ambient temperature and the presence of snow or moisture is most efficient. This cable should not be placed on a bitumen surface.

For a heat loss calculation and applicable cable, please contact the calculation department of MAGNUM Heating.



Specifications

Max. temperature	Without voltage 85°C With voltage 65°C
Min. operating temperature	- 45°C
Max. resistance	18,2 Ohm/km
Power output	Air at 10°C 20W Ice at 30W
Nominal voltage	230V
Outer jacket	Tinned copper
Coating	Aluminium foil with UV resistant TPE-O sleeve
Water resistant	100%
Dimensions	10,5 x 5,9 mm
Min. bending radius	25 mm
Weight	7,4 kg/100 m
Color	Black/UV-stable
Certification	VDE, CE
Warranty	2 year

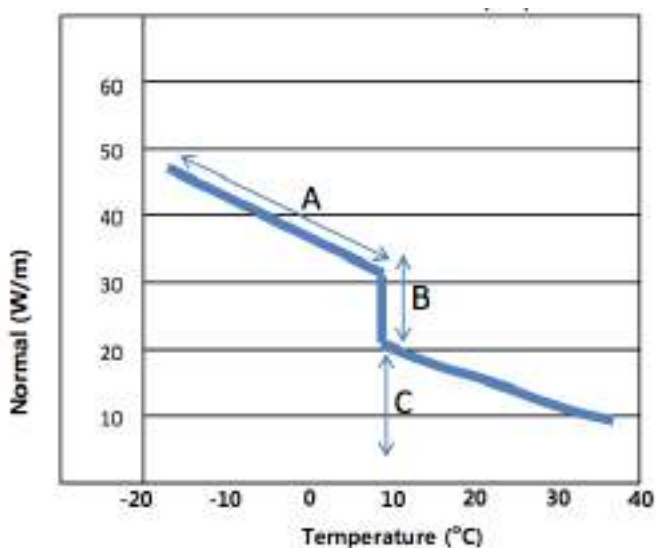

A - In snow and ice water the cable will operate at full power.
 B - When the snow melts the power will automatically decrease.
 C - The power will decrease further until all snow and ice has disappeared.



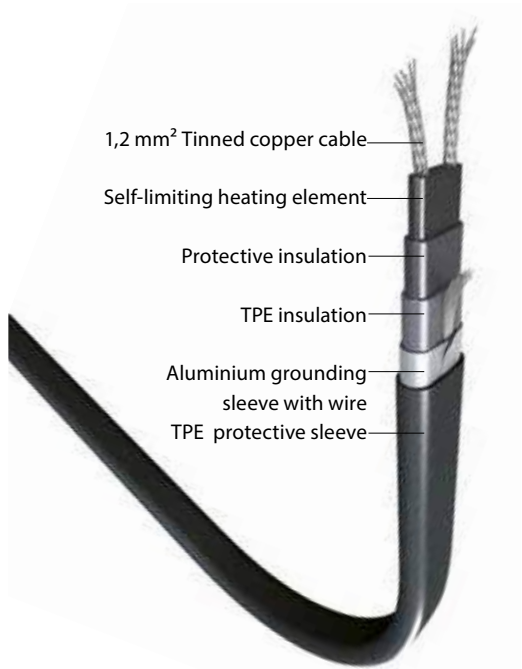

Technical details

- Max. temperature Without voltage 85°C
With voltage 65°C
- Min. operating temperature - 45°C
- Max. resistance 18,2 Ohm/km
- Power output Air at 10°C 20W
Ice at 30W
- Nominal voltage 230V
- Outer jacket Tinned copper
- Coating Aluminium foil with UV resistant TPE-O sleeve
- Water resistant 100%
- Dimensions 10,5 x 5,9 mm
- Min. bending radius 25 mm
- Weight 7,4 kg/100 m
- Color Black/UV-stable
- Certification VDE
- Warranty 2 year

Ready-to-use heating elements with built-in thermostat. Easy to use and can be installed immediately. With built-in thermostat that switches on at temperatures below 5°C and off at temperatures below -10°C and at 13°C.

Installation methods

- Check whether all necessary materials and tools are present at the construction site.
- Inspect the pipe, gutter or surface to be heated, deburring any unevenness and sharp edges or removing the sharp edges with tape.
- Remove any unevenness and sharp edges or remove the sharp edges with tape.
- Clean and dry gutters before laying the heating cable.
- Allow painted and coated pipes and surfaces to become completely dry before commencing installation.

Set contents

- Incl. connection cable 3 metres long
- 2x Bi-metal thermostat
- Mounting clips (1 per metre length)
- Metal strips for support in drainpipe

Maximum length (m) vs. size of circuit break:

Category Reference	Switch Temp.	6A	16A	20A
MTGH-20	10°C	44 m	72 m	80 m
	0°C	36 m	58 m	80 m

Art.nr.	Description	Power per metre	Volt
151020	MAGNUM Trace Gutter Heat	20 Watt @ 10°C	230V
160107	MAGNUM Support bracket for rain pipe 3 pieces		

Art.nr.	Description	Length	Power	Volt
159605	MAGNUM Trace Gutter Heat Set	5 m	100 Watt	230V
159610	MAGNUM Trace Gutter Heat Set	10 m	200 Watt	230V
159615	MAGNUM Trace Gutter Heat Set	15 m	300 Watt	230V
159625	MAGNUM Trace Gutter Heat Set	25 m	500 Watt	230V

MAGNUM Outdoor Control

Connecting materials for MAGNUM Tracing

MT - Distribution unit MTR, MTGH & MTHW

MT - Distribution unit MTM & MTW

Distribution unit (T) for connecting or splitting tracing cables.
Delivered with 2x 160103 MT-Crimp insulation end splice kits.



Connecting T-Connection



T-Junction

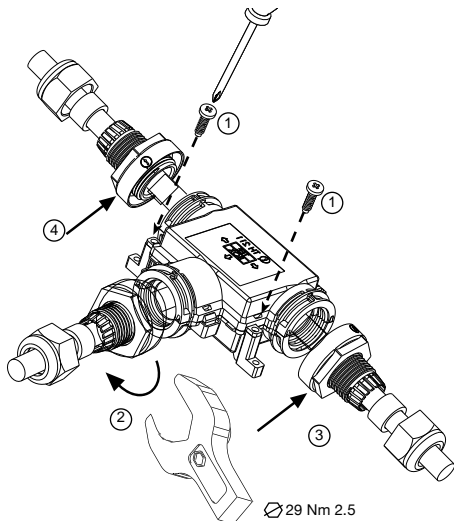

MT - Distribution unit MTR, MTGH & MTHW

MT - Distribution unit MTM & MTW

Specifications

System type	MT - Distribution unit
Dimensions	36 x 155 x 120 mm
Class	IP65
Operating temp.	-40°C up to 125°C
Inspection	CE



Art.nr.	Description
159712	MAGNUM MT - Distribution Unit (T) for MTR, MTGH and MTHW
159713	MAGNUM MT - Distribution Unit (T) for MTM & MTW

MAGNUM Outdoor Control

Connection materials for MAGNUM Tracing

MT - Connection unit MTR, MTGH & MTHW

MT - Connection unit MTM & MTW

Connector (straight) for connecting or interconnecting tracing cables. Delivered with 1 x 160103 MT heatshrink insulation end splice kit.



Connection cable



Extend cable

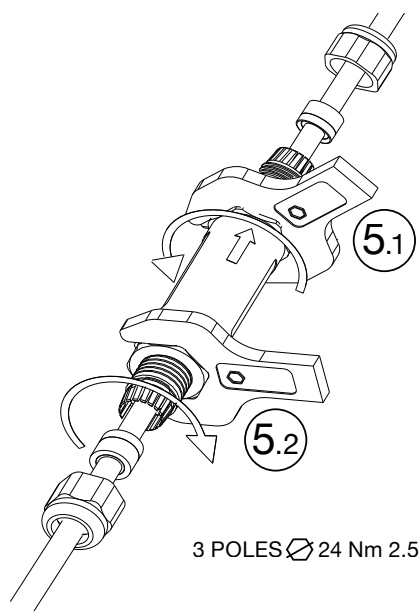

MT - Connection unit MTR, MTGH & MTHW

MT - Connection unit MTM & MTW

Specifications

System type	MT - Connection unit
Dimensions	159710: 32 mm x 130 mm 159711: 26,5 mm x 120 mm
Class	IP68 / 5 Bar
T marking	T85°C
Operating temp.	-40°C up to 125°C
Inspection	CE



Art.nr.	Description
159710	MAGNUM MT - Connecting Unit for MTR, MTGH and MTHW
159711	MAGNUM MT - Connection Unit for MTM & MTW

MAGNUM Outdoor Control Attachments for MAGNUM Tracing



MT - Connection box IP55

Connection box IP55 including DIN-rail connection clamps. For connecting or splitting several tracing cables.

Technical details

Class IP55
Dimensions 125 x 125 x 75 mm



MT - Cable gland (20 mm) for MTM, MTW and MTGH

For feeding an MTM, MTW and MTGH tracing cable into an MT connection box. One gland per cable.

MT - Cable gland (25 mm) for MTHW and MTR

For feeding an MTHW or MTR tracing cable into an MT connection box. One gland per cable.



MT - 3/4" Copper cable guide/connection for MTW

Copper cable guide for a watertight seal of the water pipe. For feeding a MAGNUM Trace Water into a water pipe with a minimum diameter of 22 mm.



Aluminium tape 50 mm x 10 metres

Especially for wrapping plastic pipework where a tracing cable is required. This tape provides increased heat dissipation in plastic pipes.

Technical details

Width tape 50 mm
Length tape 10 metres



MT - Bracket for gutter | Set of 3 pieces

These brackets support the cable and keep it in position in the gutter or drain. In gutters where 2 cables are required, these brackets ensure that the cables remain at the correct distance.



MT - Warning sticker | Set of 5 pieces

To be applied as a warning in places where tracing is installed.

Art.nr.	Description	
160105	MAGNUM MT - Connection box IP 55	
160109	MAGNUM MT - Cable gland for MTM, MTW and MTGH	20 mm
160110	MAGNUM MT - Cable gland for MTHW and MTR	25 mm
159001	MAGNUM MT - 3/4" Copper cable guide/connection for MTW	
720200	MAGNUM MT - Aluminium tape	50 mm x 10 metres
160107	MAGNUM MT - Support bracket for gutter	Set of 3 pieces
160113	MAGNUM MT - Warning sticker	Set of 5 pieces

MAGNUM ETI-1551

Thermostat for MAGNUM Outdoor systems

ETI is a series of compact ON/OFF thermostats for industrial applications, primarily ON/OFF control of a single electric heating element in floor, ceiling and radiant heating systems.

ETI thermostats are also ideal for pipe frost protection and for ON/OFF control of pumps and compressors. Furthermore, the integrated changeover relay allows ETI to be used as a cooling thermostat.

Despite their compact design, ETI thermostats are capable of handling electrical loads of up to 10A or 2200W, allowing several loads to be controlled without the necessity of installing large electrical panels. As the thermostats are also extremely robust, little or no maintenance is required.

Functions:

Adjustable temperature differential

The temperature differential around the setpoint can be adjusted to ensure a suitable ON/OFF switching frequency in relation to heating/cooling effects and sensor reaction to temperature changes. When the temperature is lower than the setpoint minus half the temperature differential, the thermostat registers a need for heating and the potentialfree relay cuts in. When the temperature is higher than the setpoint plus half the temperature differential, the relay cuts out, switching off the heating.

Visual status indication

ETI thermostats have a built-in red LED which lights up when the relay is activated. This saves time on fault finding when heating is absent.

Compact design

ETI thermostats are designed for DIN-rail mounting and are only 36 mm wide. It should therefore be easy to find room for them in most electrical panels and space is saved in the panel in comparison with conventional thermostats.

Sensor programme

MAGNUM offers a wide range of sensors in various designs suitable for use with ETI thermostats, including floor sensors, immersion sensors, machinery and equipment sensors, outdoor sensors, room sensors, duct sensors, pipe sensors and wall sensors. For further information on sensors, see ETF data sheet.



Specifications

Supply voltage	230V AC \pm 10%, 50-60 Hz
Sensor input	NTC
Relay output	SPCO 10A, 250V AC
Setpoint adjustment	-10°C / +50°C
Temperature differential	0,3°C - 6°C
Ambient temperature	0°C / +50°C
Power consumption	3VA
Max. fuse rating	10A, Type g
Housing	IP20
Weight	170 g
Dimensions	36 x 58 x 86 mm (H/W/D)
Inspection	CE



Technical details

ETI-1551 Thermostat installation

ETI thermostats are designed to be mounted on a DIN rail inside an enclosure with a suitable rating. A wall-mounting enclosure is available as an accessory.

Cable connection

The sensor cable may be extended up to 100 m. The sensor cable must be kept separate from mains-carrying cables as disruptive voltages may be induced. The sensor cable need not be screened, but the use of screened cable increases ETI resistance to interference, which is particularly important in industrial installations. The screen must be connected by a bracket to an earthed metal backplate or direct to an earth terminal.

Room sensors

Room sensors should be positioned on the wall in such a way as to allow free air circulation around them. They must also be positioned so as to prevent them being affected by direct heat sources (e.g. the sun), draughts from doors and windows, or outside temperature (i.e. do not mount on outer wall).

Floor sensors

Floor sensors should be installed in standard conduit embedded in the floor between heating cables, preferably as close to the floor surface as possible.

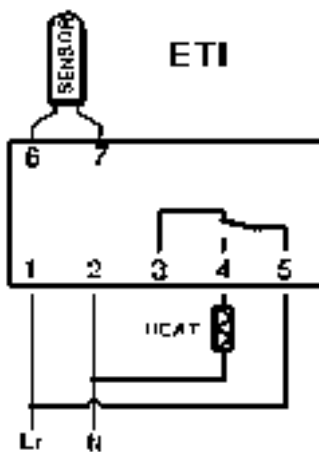
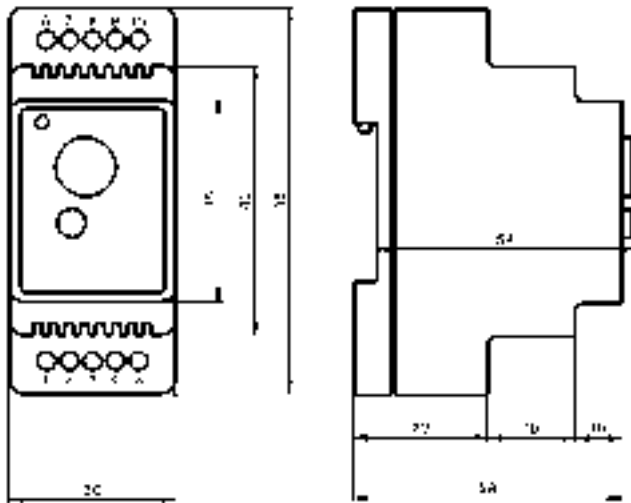

Art.nr.	Description	Volt
891551	MAGNUM Thermostat ETI-1551 DIN-rail -10°C/+50°C 10A	230V

MAGNUM ETR-2

Thermostat for MAGNUM Outdoor systems

An intelligent all-in-one solution for ice and snow melting suitable for any application which uses hydronic or electric heating. Optimal operation is ensured through output control, making the system both effective and economical. ETR-2 offers the possibility of snow melting - the green way.

MAGNUM has developed the ETR-2 controller for ice and snow melting in gutters or small ground areas. Using readings from temperature and moisture sensors, the controller ensures economical control of power consumptions when keeping outdoor areas or roofs free of ice and snow. The moisture sensor is installed in the surface of the outdoor area or placed in the gutter. As soon as moisture is detected, the ETR-2 controller activates the snow melting system. Once the sensor has dried out, the thermostat immediately goes in afterrun and the system will continue to provide heat for a chosen time.

The ETR-2 gives an economical control of ice-and snow melting for all smaller applications. With focus on power consumption and easy installation, the ETR-2 keeps gutters and small ground areas free of ice and snow.

Functions:

- Economical control of ice and snow melting in the outdoor area and gutters
- Detection of temperature and moisture
- Electronic on/off control up to 3,600W
- For roof or gutter applications
- Easy to install
- Adjustable moisture sensitivity
- Possibility to activate forced heat



Specifications

Supply voltage	230V ±10% 50/60 Hz
On/off differential	0,4°C
Setting of temperature	0°C - 10°C
Setting of afterruntime	0 - 5 hours
Output relays	16A potential-free 3600W
Power consumption	3VA
Temp. range (ambient)	0°C /+50°C
Housing	IP20
Weight	190 g
Dimensions	86/52,5/58 mm (H/W/D)
LED indication:	Green: Power on Red + moist: Moisture detected Red + temp.: Temp. below setpoint Red + relay: Output on
Inspection	CE



Technical details

ETR-2 Easy startup:

Adjust the temperature and the afterrun time. The thermostat is now working when the outdoor temperature is below the set temperature.

Suitable sensors for outdoor surfaces:

ETOG-56

The ETOG sensor is designed for embedding in the surface of the outdoor area. ETOG sensors measure ground temperature and moisture.



ETF-744/99

The ETF-744/99 sensor can be used for measuring rapid temperature drops.



Suitable sensors for gutters:

ETOR-55

The ETOR sensor is designed for installation in gutters, downpipes, etc. ETOR sensors detect moisture.



ETF-744/99

The ETF-744/99 sensor can be used for measuring rapid temperature drops.

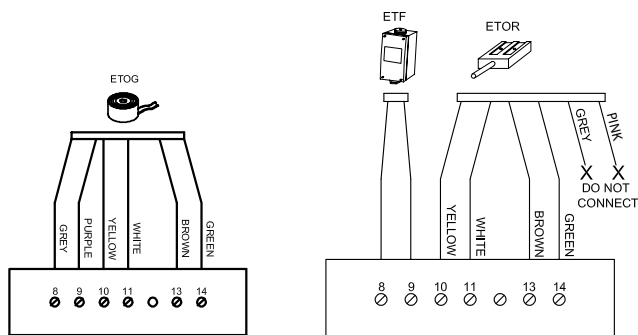
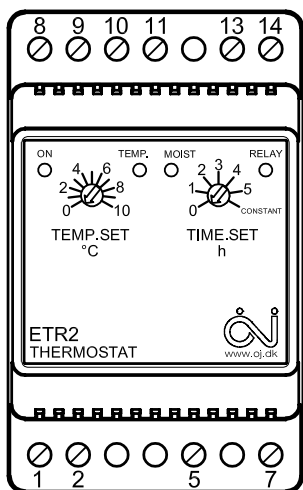
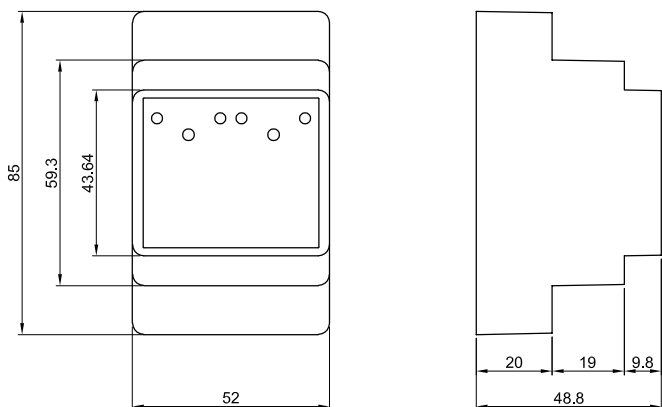

Art.nr.	Description	Volt
900056	MAGNUM Thermostat ETR-2 DIN-rail temp./moisture 1x16A	230V

MAGNUM ETN-4

Thermostat for MAGNUM Outdoor systems

An intelligent all-in-one solution for ice and snow melting suitable for any application which uses hydronic or electric heating. Optimal operation is ensured through output control, making the system both effective and economical. ETN-4 offers the possibility of snow melting - the green way.

MAGNUM has developed the ETN-4 controller for ice and snow melting on the ground and in gutters. Using readings from temperature and moisture sensors, the controller ensures economical control of power consumption while keeping outdoor areas and roofs free of ice and snow. The moisture sensor should be installed in the ground surface or placed in the gutter. As soon as moisture is detected in conjunction with low temperature, the ETN-4 controller activates the snow-melting system. Once the sensor has dried out, the thermostat immediately goes into afterrun and the system continues to provide heat for a set time.

An "all-in-one" thermostat with extended temperature control range, suitable for a wide range of applications. Easy to operate and programme.

The "all-in-one" thermostat comes with room sensing, room sensing and floor limitation, floor sensing mode only and regulator mode. If you need a thermostat for floor heating control, sauna, frost protection of pipes or cooling applications, the ETN4-1999 is an obvious choice.

Large differential temperature range

The thermostat has a large differential temperature range of 6°C, for either lowering the cycle time of the relay or specifically to reduce the number of start cycles.



Specifications

Supply voltage	230V AC \pm 10% 50/60Hz
Standby power	0,5 Watt
Output relay SPST	16A, resistive load or 1A inductive load
Interrupter	2-pole, 16A
Control temperature range (extended)	-19,5°C to +70°C
Control accuracy	\pm 0,4°C
Floor limit range	-19,5°C / +70°C
Ambient temperature	-19,5°C / +55°C during operation
Night setback relative	-19,5°C / +30°C
Night setback regulator	1-100%
Frost protection Abs.	0°C - 10°C
Frost protection regulator	1-100%
Regulation principle	PWM/PI or ON/OFF
Housing	IP20
Sensor type	NTC (12 K Ω) 3 m max. 100 m
Display	Segment – backlit
Dimensions	88,5/52,9/57,3 mm (H/W/D)
Inspection	CE



Technical details

Functions:

- The "all-in-one" thermostat is perfect for the application types:
 - Electrical floor heating
 - Frost protection
 - Ice & Snow melting
 - Cooling
- Extended temperature range $-19,5^{\circ}\text{C}$ to $+70^{\circ}\text{C}$
- Input for night setback and frost protection
- Now also with cooling application invertible relay function and differential temperature
- Optimum safety due to built-in 2 pole 16 Amp interrupter
- Easy menu navigation and programming
- Programming is easy, ensuring the fastest and easiest set-up
- Big backlit display
- Delivered with new thin floor sensor, which makes mounting of sensor more comfortable than ever

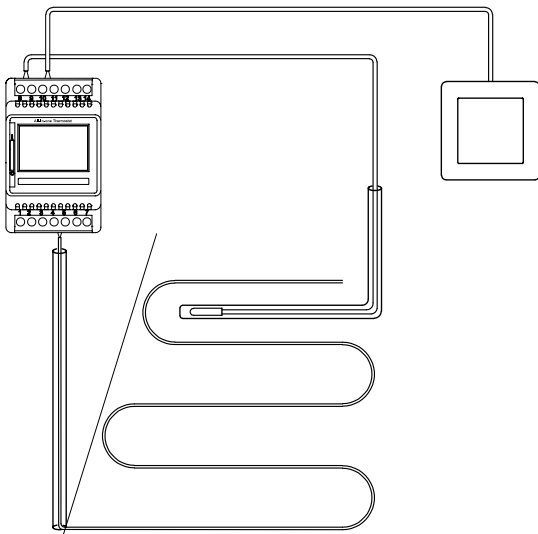
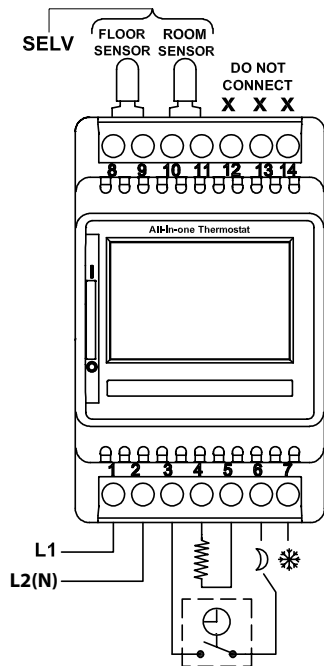

Art.nr.	Description	Volt
892551	MAGNUM Thermostat ETN-4 Digital DIN-rail $-20^{\circ}\text{C}/+70^{\circ}\text{C}$ 16A	230V

MAGNUM ETO2-4550

Thermostat for MAGNUM Outdoor systems

An intelligent all-in-one solution for ice and snow melting suitable for any application which uses hydronic or electric heating. Optimal operation is ensured through output control, making the system both effective and economical. ETO2 offers the possibility of snow melting - the green way.

MAGNUM has developed the ETO2 controller for ice and snow melting on the ground and in gutters. Using readings from temperature and moisture sensors, the controller ensures economical control of power consumption while keeping outdoor areas and roofs free of ice and snow. The moisture sensor should be installed in the ground surface or placed in the gutter. As soon as moisture is detected in conjunction with low temperature, the ETO2 controller activates the snow-melting system. Once the sensor has dried out, the thermostat immediately goes into afterrun and the system continues to provide heat for a set time.

Complete watertight switch boxes manufactured and fitted according to the number of cables/mats and power. The system can be supplied in both 230V and 400V.

Functions:

- Temperature & humidity 3 x 16A - 230V
- Electronic on/off control up to 11kW
- 2 zone control, at the same time individually controllable
- Economic control, minimum energy consumption
- Adjustable moisture sensitivity
- Measurement of both temperature and moisture
- Control of hydronic or electric ice and snow melting systems
- Display and "turn-and-push" button for easy programming
- Language options



Specifications

Supply voltage	120 - 240 V ±10%, 50 - 60 Hz
Temp. range (control)	-20°C / +50°C
Built-in timer for manual snow melting / afterrun	0 - 18 hours
Output relays	3 x 16 A potential-free relays
2-zone application	Via 2 x 16 A potential-free output relays
Hydronic system	Control of 3 or 4 way valve, primary pump, secondary pump
Display	Graphic, backlit
Temp. range (ambient)	0°C / +40°C
Temp. range (storage)	-50°C / +70°C
Housing / incl. cover	IP20
Weight	495 g
Dimensions excl. cover	90/156/45 mm (H/W/D)
Dimensions incl. cover	170/162/45 mm (H/W/D)
LED indication:	Green: ON Red: Error
Keuring	CE



Technical details

ETO2 4550 thermostat installation:

DIN-rail mounting in electrical cabinet, MAGNUM mounting box or on a wall surface.

Suitable sensors for outdoor surfaces:

ETOG-56

The ETOG sensor is designed for embedding in the surface of the outdoor area. ETOG sensors measure ground temperature and moisture.



ETF-744/99

The ETF-744/99 sensor can be used for measuring rapid temperature drops.



Suitable sensors for gutters:

ETOR-55

The ETOR sensor is designed for installation in gutters etc. ETOR sensors detect moisture



ETF-744/99

The ETF-744/99 sensor can be used for measuring rapid temperature drops.

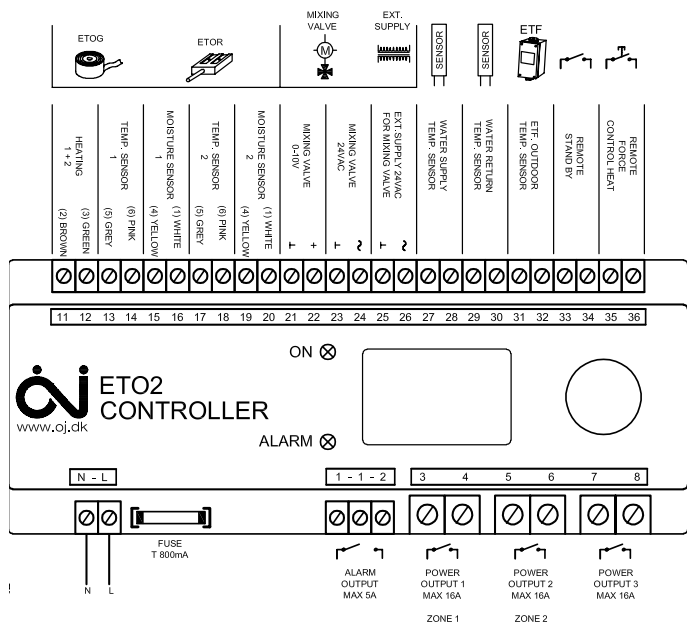
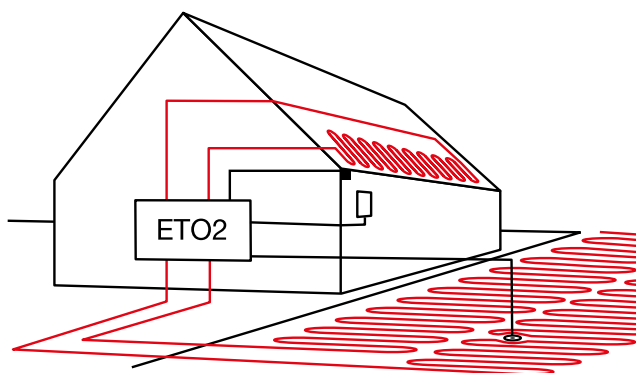
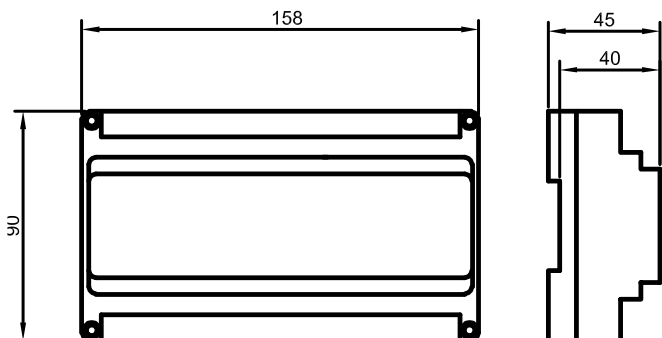

Art.nr.	Description	Volt
893550	MAGNUM Thermostat ETO2-4550 DIN-rail temp./moisture 3 x 16A	230V

MAGNUM ETOG-56

Sensor for MAGNUM Outdoor systems

Ground sensor type ETOG-56

Designed for embedding in the outdoor surface using the ETOK-1 sensor tube. Detects both temperature and moisture.

Sensor tube ETOK-1

Mounting tube for ETOG-56, supplied with a wood plug for covering the ETOK-1 hole during installation. Notch on side for conduit.

Mounting of sensor tube ETOK-1

The sensor should be mounted in an open unsheltered location away from walls, etc. The tube must be embedded with its top completely horizontal and flush with the surrounding surface. It should be embedded in a hard surface, e.g. concrete or asphalt. A conduit, up to \varnothing 23 mm, must be inserted into the notch. It is recommended that the conduit be equipped with a cord in order to make it easier to pull the cable through. The accompanying wood plug must be placed in the hole before the concrete or asphalt is applied. Ensure that it is securely embedded in relation to the expected surface load.

Mounting of ground sensor ETOG-56

After the concrete/asphalt has cured, the sensor can be mounted. Remove the wood plug from the tube and ensure that the tube is clean. Pull the cable through the conduit, ensuring that the cable is not damaged on any sharp edges. Place the sensor in the tube. The sensor cable must fit easily through the hole in the bottom. The accompanying screw must be fitted in the middle of the sensor and securely tightened.

Mounting of sensor cable

The cable must be mounted in accordance with applicable local regulations. The cable must never be installed parallel to power cables as electrical interference may distort the sensor signal. The sensor is supplied with 25 m cable which can be extended up to 200 m using standard installation cable: $6 \times 1,5 \text{ mm}^2$. The total resistance of the cable must be less than 10 ohm.

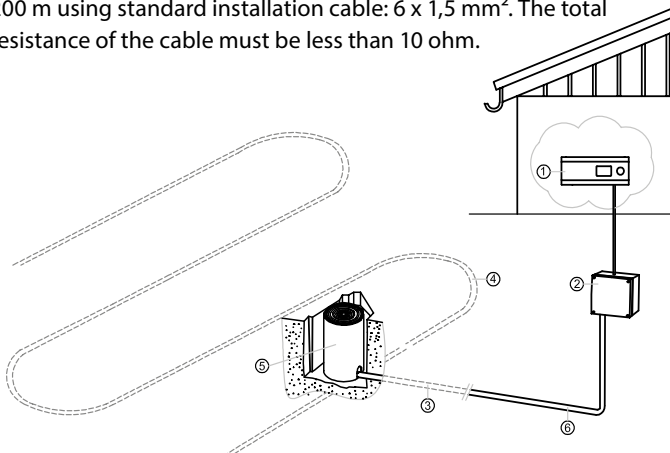

Specifications

Detection	Moisture and temperature
Mounting	Outdoor surface
Cable length	25 m
Enclosure rating	NEMA 6P/IP 68
Temp. range (ambient)	-50°C / +70°C
Dimensions (sensor)	H32, \varnothing 60 mm
Dimensions (tube)	H78, \varnothing 63,5 mm
Heating (brown, green)	224 Ohm
Moisture (yellow/white)	0 Ohm (normally no value, with moisture: full lock)
Temperature sensor depending on temp.	-4 °C : 43 K/Ohm -2 °C : 39 K/Ohm 0 °C : 35 K/Ohm 2 °C : 32.4 K/Ohm 4 °C : 29.8 K/Ohm 5 °C : 27 K/Ohm 10 °C : 22 K/Ohm
Keuring	CE



Art.nr.	Description
890065	MAGNUM Sensor unit ETOG-56 temp./humidity for road surfaces

MAGNUM ETOR-55

Sensor for MAGNUM Outdoor systems

Gutter sensor type ETOR-55 + 10 metres connection cable

Designed for mounting in gutters and down pipes ect. Detects moisture and is mounted in combination with outdoor sensor ETF for temperature detection. Only to be used in combination with outdoor sensor type ETF-744/99.

Mounting of sensor

To be mounted in the gutter or downpipe on the sunny side of the building. Contact points of the sensor must be placed towards the flow of the melting water. To be mounted where the melting water will often appear.

Mounting of sensor cable

The cable must be mounted in accordance with applicable local regulations. The cable must never be installed parallel to power cables as electrical interference may distort the sensor signal. The sensor is supplied with 10 m cable which can be extended up to 200 m using standard installation cable: 6 x 1,5 mm². The total resistance of the cable must be less than 10 ohm.

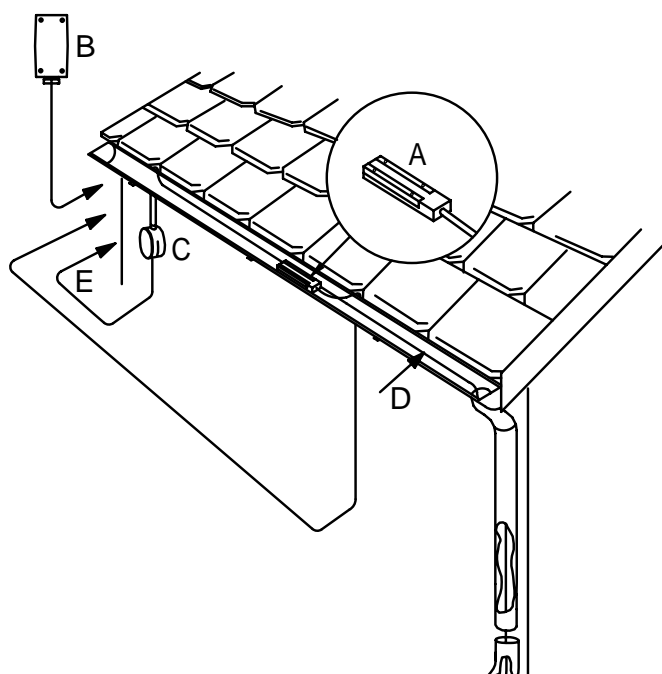

Specifications

Measurement	Moisture
Installation	Gutter or downpipe
Housing	IP68
Temp. range (ambient)	-50°C / +70°C
Dimensions	105/30/13 mm (H/W/D)
Keuring	CE



Art.nr.	Description
900055	MAGNUM Sensor unit ETOR-55 moisture for the (roof) gutter

MAGNUM ETF-744/99

Sensor for MAGNUM Outdoor systems

The snow melting system is only energized when the outdoor temperature drops below the selected setting and snow or ice is detected by the sensors. Energy is therefore used only when absolutely necessary.

ETF-744/99 External Outdoor Temperature Sensor

This outdoor sensor only records the temperature. To be used in combination with outdoor sensor type ETOR-55 or only for temperature recording.

For gutters - ETO2-4550, ETOR-55 and ETF-744/99

The ETOR sensor is designed for installation in gutters, downpipes, etc. ETOR sensors detect moisture, while ETF sensors measure temperature.

ETF outdoor temperature sensor

Measures temperature. Is normally used in combination with ETOR gutter sensors, but can also be used separately for temperature measurement only. An ETF sensor can also be used in combination with ETOG ground sensors for outdoor areas. The ETF sensor can detect rapid drops in air temperature, avoiding icy areas.

ETF outdoor temperature sensor installation

Should be installed beneath the eaves on the northern side of the building.



Specifications

Measurement	Temperature
Installation	Wall surface
Housing	IP54
Temp. range (ambient)	-50°C / +70°C
Dimensions	86 x 45 x 35 mm (H/W/D)
Inspection	CE



Art.nr.	Description
901441	MAGNUM Sensor unit ETF-744/99 External outside temperature sensor

MAGNUM ETF-633/44/55

Sensor for MAGNUM Outdoor systems

ETF is a complete series of temperature sensors designed for temperature control and monitoring in heating and cooling systems.

All common sensor types are available in a wide range of mechanical types. The specific requirements of individual applications can therefore always be met.

The ETF series also contains sensors dedicated to the temperature controllers from MAGNUM. ETF sensors thus provide optimum temperature control.

ETF sensors are designed to provide our customers with an advantageous combination of high quality, accurate measurement and low life cycle costs.

Many Mechanical Types

Thanks to the many mechanical types, a single supplier can provide ideal sensors for temperature measurement in everything from large tank installations and cold-storage facilities to residential living rooms. Sensors can be custombuilt to order.



Specifications

Detection	Temperature
Type	NTC, 12k Ω / 25°C
Cable length	2,5 m
Enclosure rating	IP54
Temp. range (ambient)	-40°C / +120°C
Dimensions	8 x 12mm, \varnothing 3,5 mm hole
Inspection	CE



Art.nr.	Description
891650	MAGNUM Sensor unit ETF-633/44/55 Pipe sensor -20°C /+70°C

MAGNUM ETF-144

Sensor for MAGNUM Outdoor systems

ETF is a complete series of temperature sensors designed for temperature control and monitoring in heating and cooling systems.

All common sensor types are available in a wide range of mechanical types. The specific requirements of individual applications can therefore always be met.

The ETF series also contains sensors dedicated to the temperature controllers from MAGNUM. ETF sensors thus provide optimum temperature control.

ETF sensors are designed to provide our customers with an advantageous combination of high quality, accurate measurement and low life cycle costs.

Many Mechanical Types

Thanks to the many mechanical types, a single supplier can provide ideal sensors for temperature measurement in everything from large tank installations and cold-storage facilities to residential living rooms. Sensors can be custombuilt to order.



Specifications

Detection	Temperature
Mounting	Floor
Cable length	2,5 m
Enclosure rating	IP54
Temp. range (ambient)	-20°C / +70°C
Inspection	CE



Art.nr.	Description
860199	MAGNUM Sensor unit ETF-144 Floor sensor (12k) -20°C/+70°C

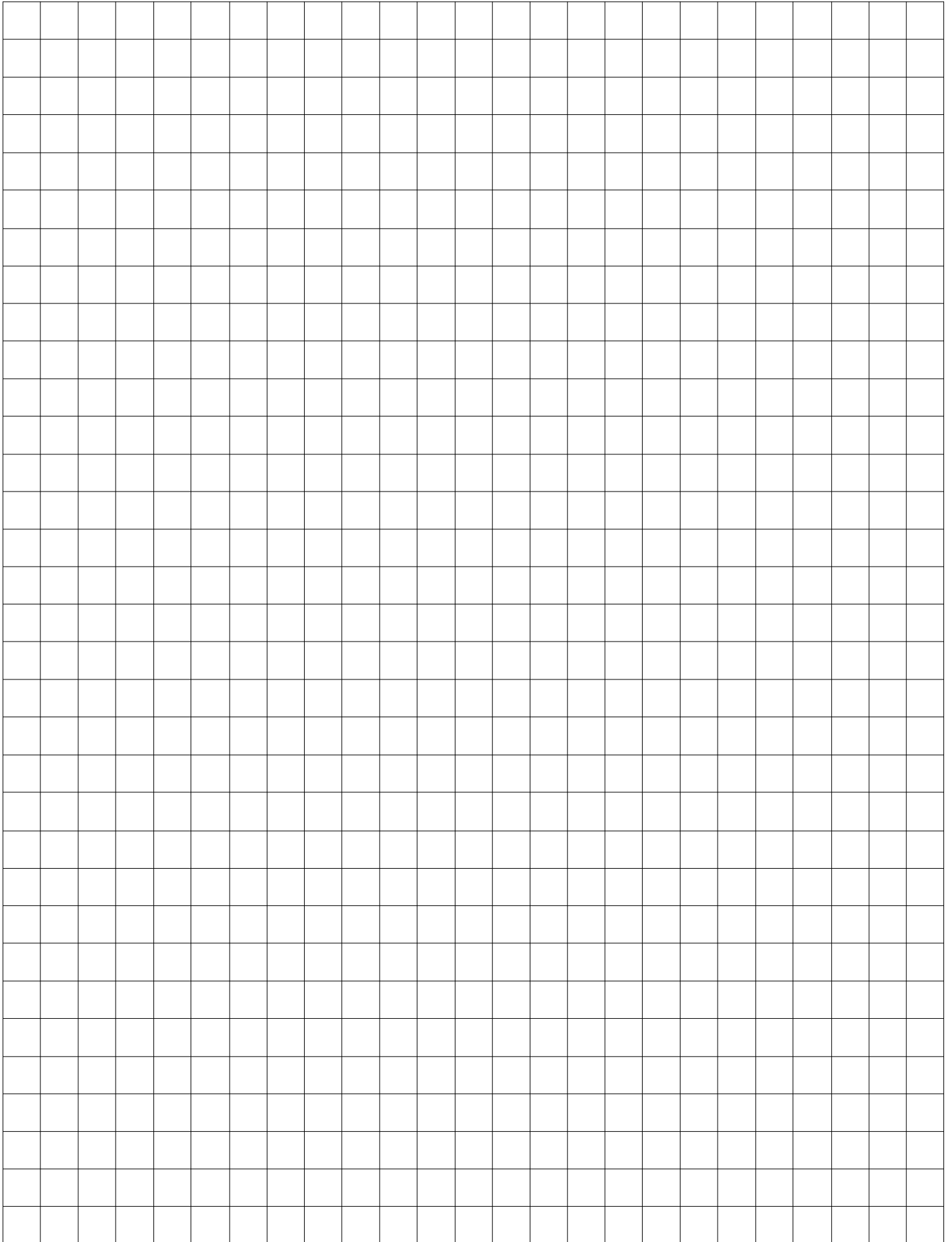

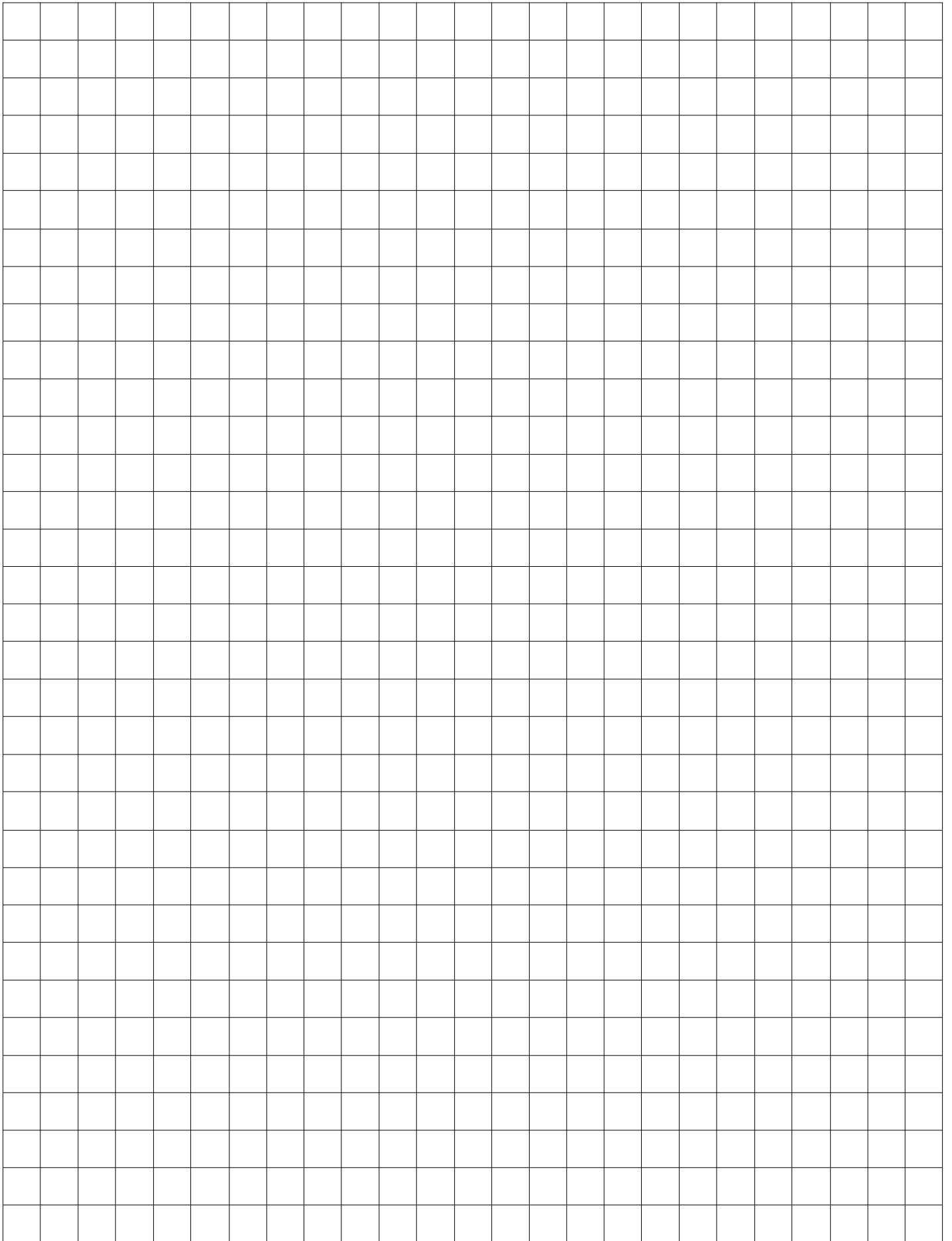

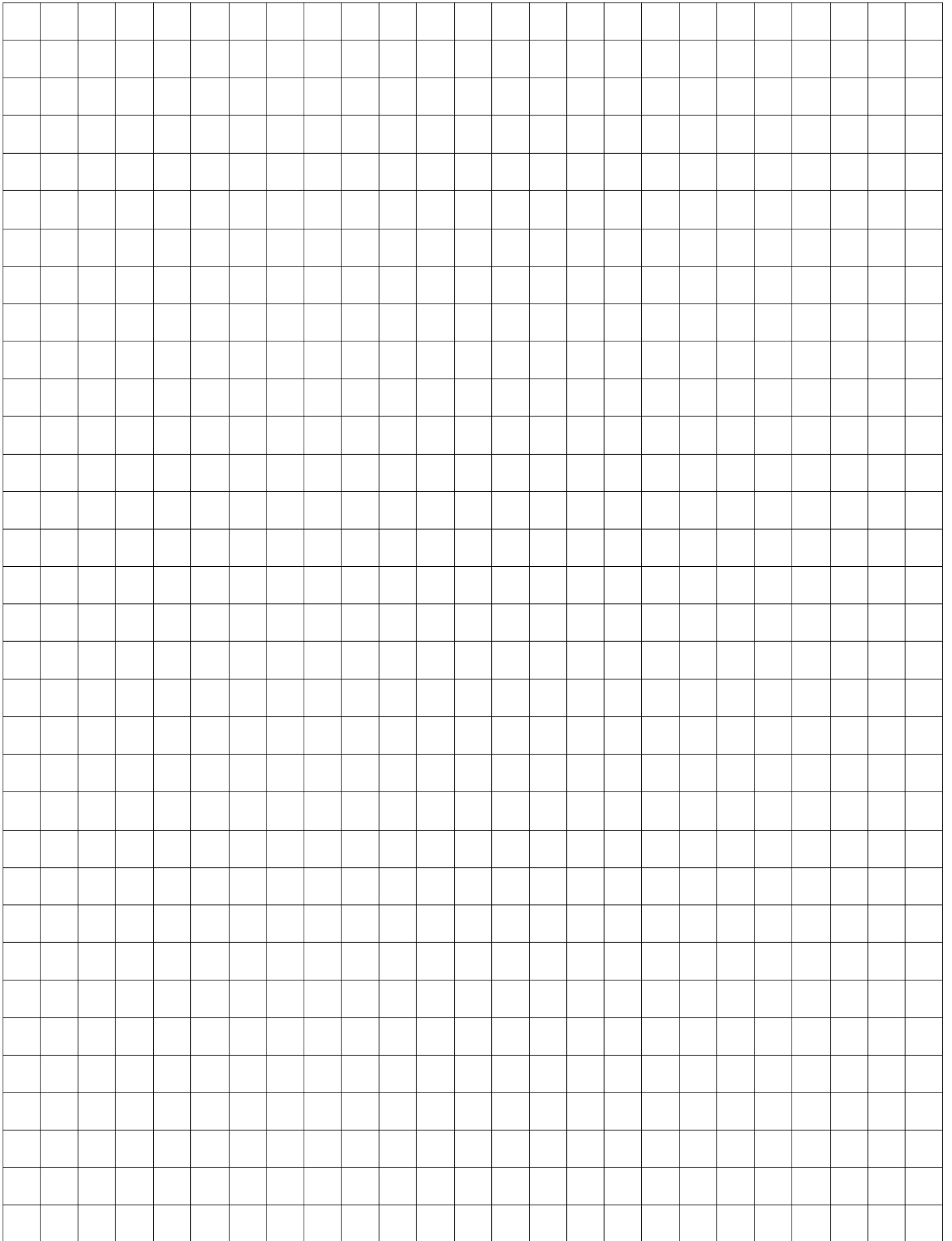



MAGNUM Heating B.V.
Stevinweg 8
4691 SM Tholen

T +31(0)166-609 300
E info@magnumheating.com
W magnumheating.com